

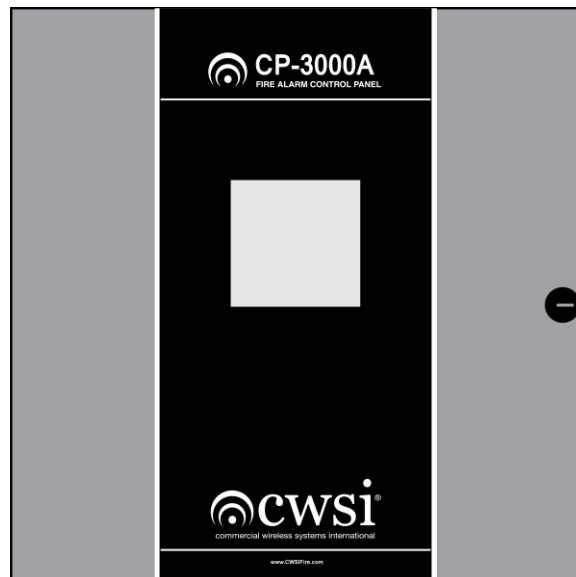

CP-3000A WIRELESS FIRE ALARM CONTROL PANEL



OPERATING and INSTALLATION INSTRUCTION MANUAL

CWSI, LLC
10798 N.W. 53 Street
Sunrise, Florida 33351

Disclaimer

The information contained in this document is believed to be accurate and reliable at the time of printing. Known corrections or omissions may be found on errata sheets included in the various product manuals. However, Commercial Wireless Systems International, LLC herein known as CWSI, may not be held accountable for errors or omissions in this or other CWSI publications. No license is granted by implication or otherwise under any patent rights of CWSI

CWSI makes no claims as to the suitability of their products for a specific installation site or for a specific application. Local testing for suitability of both the proposed site and application is required.

Unless prohibited by law, the liability of CWSI is limited to the cost of the equipment supplied by CWSI or their authorized agent. The liability of CWSI for defective product is limited to the repair or replacement of the defective product at the option of CWSI. CWSI is not liable for, nor will reimbursement be made for the removal of, or replacement of the defective equipment or for the inconvenience or supplemental costs which may be incurred by the installer, installing company, dealer or end user of the equipment.

All guarantees or warranties on the products are limited to those published by CWSI and no others, given verbally or in writing are valid except when signed specifically by the president of CWSI.

Table of Contents

CP-3000A WIRELESS FIRE ALARM CONTROL PANEL.....	1
OPERATING and INSTALLATION.....	1
INSTRUCTION MANUAL.....	1
DISCLAIMER.....	2
INTRODUCTION	6
FCC Warning – RF Exposure	6
FCC Warning.....	6
SECTION 1 - DESCRIPTION AND FEATURES	7
1.1 Product Description and Wireless System Overview	7
1.2 Features.....	8
SECTION 2 – SPECIFICATIONS AND COMPATIBILITY.....	9
2.1 Specifications	9
2.2 Compatibility	10
2.3 UL Restricted Programming Options.....	10
SECTION 3 - INSTALLATION.....	12
3.1 Proper Installation Order.....	12
3.2 Preparing the Installation Site	12
3.3 Receiving and Unpacking the Equipment	12
3.4 Installing the CP-3000A.....	12
3.4.1 Enrolling Devices, annunciators and repeaters	16
3.4.2 Installing the Annunciators, Repeater and Initiating Devices.....	17
3.4.3 The Backup Batteries.....	18
3.4.4 Cover Panel	18
SECTION 4 - SYSTEM PROGRAMMING	20
4.1 Keypad Buttons and Menu Navigation	20
4.2 Menu Selection and Navigation	21
4.2.1 Menu Basics	21
4.2.2 Menu Selections	21
4.2.3 Menu Access, Navigation, Data Entry and Field Editing	23
4.3 Initial System Configuration	25
4.3.1 Set Time and Date	26
4.3.2 Password Reset.....	26
4.3.3 Base code Setup.....	27
4.4 Device, Annunciator, Repeater and CP3000A Info Programming	28
4.4.1 Accessing the Device Edit screen	28
4.4.2 Deleting a Device, annunciator or repeater	30
4.4.3 Device Zone Assignment	30
4.4.4 Alarm Priority Assignment.....	31
4.4.5 Selecting the Device Type	31
4.4.6 Entering Device, Annunciator and Repeater Description	32
4.5 NAC and Relay Box Programming	33
4.5.1 Accessing the Repeater Relay Setup screen	33

4.5.2 CP-3000A and Repeater NAC and Relay Box Programming.....	34
4.6 CP-3000A Auxiliary Output and Dry Contact Relay Programming	35
4.6.1 Accessing the CP-3000A Relay Setup Screen.....	35
4.6.2 CP-3000A Relay Programming	36
4.7 Supervisory Setup	36
4.7.1 Accessing the Supervisory Setup Screen.....	37
4.7.2 Programming the Sprinkler Supervisory Feature	37
4.8 Device Programming and Options	38
4.8.1 Accessing the Tandem Control Menu.....	39
4.8.2 Programming Tandem Manual Activation and Deactivation.....	39
4.8.3 Remote Reset Feature.....	40
4.9 Unknown and Ignored Units	40
4.9.1 Displaying the Unknown Unit Screen	41
4.9.2 Removing a Device from the Unknown List.....	41
4.9.3 Displaying the Ignored Unit Screen	42
4.9.4 Removing a Device from the Ignored List.....	42
SECTION 5 - SYSTEM OUTPUTS	44
5.1 Dry Contact Outputs.....	44
5.1.1 Alarm A, B, C, D Contacts (TB2 Terminals 17-24)	44
5.1.2 Trouble Contacts (TB2 Terminals 13-16 N.O. and TB3 Terminals 3-6 N.C.).....	44
5.1.3 Relay 1+2 form C Outputs (TB3 Terminals 7-12)	45
5.2 NAC Auxiliary and Other Outputs	45
5.2.1 Auxiliary Output Local Energy Municipal Box Service (TB4 Terminals 1+2).....	45
5.2.2 Notification Appliance Circuits (TB1 Terminals 1-4 on receiver card)	47
5.2.3 Notification Appliance Compatibility.....	48
5.2.4 RS-232 Serial Connector	49
5.2.5 Ethernet Connection	49
5.2.6 USB Connector	49
5.2.7 Relay Expansion Connector	49
SECTION 6 - SYSTEM INTERFACE AND OPERATION.....	49
6.1 Visual Displays, User Interface and Internal Sounder	49
6.1.1 LCD.....	49
6.1.2 LEDES.....	50
6.1.3 Buttons	50
6.1.4 Sounder	53
6.2 System Operation	53
6.2.1 General	53
6.2.2 Normal Standby	54
6.2.3 Alarm.....	54
6.2.4 Sprinkler Supervisory.....	55
6.2.5 Trouble Signals	56
6.2.6 System Test.....	58
6.2.7 Event Logs	59
6.2.8 System and Programming Information	61
6.2.9 Accessing the System Info Screen	61
6.2.10 Accessing the Programming info Screen.....	62

SECTION 7 - DIGITAL ALARM COMMUNICATOR64
7.1 Installation and Wiring64
7.1.1 Installation..... 64
7.1.2 Wiring..... 65
7.2 Programming and Operation65
7.2.1 Programming 65
7.2.2 Operation 66

SECTION 8 – SIGNAL SURVEY67
8.1 New Installation Survey.....67
8.2 Existing Installation Survey68

MODEL CP-3000A OPERATING INSTRUCTIONS71



Introduction

This manual is intended for persons involved with the installation, maintenance and operation of the CP-3000A RF control panel. It is a comprehensive guide that provides details on product operation and should be kept for future reference. This manual consists of separate sections. Each section contains information in a manner as to be clear as possible. It is designed to provide all the information necessary to install, program and operate the equipment. Read and understand this manual prior to installing or operating the equipment. It is imperative that the installer understand the requirements of the Authority Having Jurisdiction (AHJ) and be familiar with the standards set forth by Underwriters Laboratories, NFPA 72 National Fire Alarm Code, and NFPA 70 National Electrical Code.

The model CP-3000A is the first in a series of wireless fire annunciation and control panels manufactured by CWSI. This system was designed and tested to comply with **NFPA 72 National Fire Alarm Code and UL 864 standard. The CP-3000A is approved for Local, Remote Station, Central Station and Auxiliary service when installed in accordance with this manual.**

FCC Warning

Important: Any changes or modifications not expressly approved by the party responsible for compliance could void the user's authority to operate the equipment.

This device complies with part 15 of the FCC Rules. Operation is subject to the following two conditions: (1) This device may not cause harmful interference, and (2) this device must accept any interference received, including interference that may cause undesired operation.

FCC Warning – RF Exposure

Important: When using this device, a certain separation distance between antenna and nearby persons has to be kept to ensure RF exposure compliance. In order to comply with the RF exposure limits established in the ANSI C95.1 standards, the distance between the antennas and the user should not be less than [20cm].

Section 1 - Description and Features

1.1 Product Description and Wireless System Overview

The CWSI CP-3000A is an intelligent addressable wireless fire alarm control panel. The CP-3000A system provides for annunciation of up to 1024 individual addressable initiating devices including smoke detectors, fire transmitters and repeaters. It has two on board transceivers that allows all communications with devices to be done via radio frequency (RF) however only the antenna "A" transceiver is used in the CP-3000A. Since the communications are bi-directional the control panel can send out control commands to perform functions including turning on or off repeater NAC circuits and tandem smoke detector sounder activation. The advanced RF protocol and speed of the CP-3000A allows a trouble with any one of up to 1024 initiating devices to be reported within 200 seconds. The CP-3000A is field programmable making the addition of devices both easy and cost effective. An internal piezo sounder provides distinct tones for alarm, supervisory and trouble signals. The system contains a clock and non volatile memory that will record and store events by time and date of occurrence. The CP-3000A is capable of storing 4000 events for later viewing as outlined in the event log section of this manual.

The unit is also compatible with a UL Listed Communicator making the CWSI CP-3000A a complete installation solution. The system is designed with monitoring and emergency personnel in mind. The LCD display provides easily identifiable pinpoint information displaying the specific initiating device(s) in alarm, trouble or supervisory condition. A 21 button membrane switch panel is used for system control and programming. The CP-3000A notification appliance circuits are field selectable both for 12 or 24 volt DC and Class A or B operation.

The CWSI initiating devices contain microprocessor based transceivers and are battery powered. Bi-directional repeaters are used to create a cellular network type signaling path to and from the CP-3000A control panel. Initiating devices transmit both status and alarm information. Repeaters process the data and retransmit the data through the repeater network to and from devices and the CP-3000A control panel. All transmitted signals are verified for data integrity, signal quality and reception conformation. The CP-3000A is responsible for reading all incoming transmission data displaying information, sending commands back to repeaters to activate Notification appliance circuits, HVAC shutdown, Elevator Recall, Tandem smoke detectors and many other control functions depending on the particular application. Alarm, Supervisory and Trouble signals can be viewed at up to 8 remote locations with the compatible WRA-3 remote annunciator.

The CP-3000A control panel has many new and enhanced features unavailable in previous wireless systems due to recent technological advances. These features and industry advancements are what make CWSI the unsurpassed leader in the wireless fire alarm industry.

1.2 Features

- 1024 device capability
- 4 alarm types
- Bi-Directional RF communication
- 900 Mhz Frequency Hopping Spread Spectrum format
- CRC data validation
- Dual transceiver design
- Tandem smoke detector control
- 24 or 60 hour battery standby time
- Field selectable NAC circuits Voltage and Class
- 4 N.O. alarm dry contact outputs
- 2 form C programmable dry contact alarm outputs
- 2 form C trouble outputs
- Auxiliary municipal city box output
- 320 x 240 backlit LCD display
- Time and date with daylight savings self adjustment
- Device enrollment feature
- Password and key lock protected non volatile memory
- User changeable password
- 21 button membrane pad
- Field programmable
- Pinpoint signal identification
- History of events for
 - ✓ 1000 alarm/supervisory signals
 - ✓ 1000 trouble signals
 - ✓ 1000 test log signals
 - ✓ 2000 all events log

Section 2 – Specifications and Compatibility

2.1 Specifications

Power Source: 120 VAC 60Hz 4 Amp dedicated circuit.

Batteries: Two 12Vdc 4Ah sealed lead acid batteries connected in series for up to 24 hours standby operation or two 12Vdc 7Ah sealed lead acid batteries connected in series for 60 hours standby operation. Use only Genesis/Energys batteries P/N NP4-12 for 24 hour standby or NP7-12 for 60 hour standby.

Operating Temperature: 32 to 120 degrees F

Operating Humidity: 85% non condensing

Special Application NAC Circuits: Programmable Non Power Limited. 1 Class “A” (Style Z) or 2 Class “B” (Style Y) Field selectable.

Class A ratings: 12 Volts DC @ 1.75 Amps or 24 Volts DC @ 1 Amp

Class B ratings: 12 Volts DC @ 1.75 Amps each or 24 Volts DC @ 1 Amp each

Regulated NAC Circuits: Programmable Non Power Limited. 1 Class “A” (Style Z) or 2 Class “B” (Style Y) Field selectable.

Class A ratings: 12 Volts DC @ 175 Milliamps or 24 Volts DC @ 100 Milliamps

Class B ratings: 12 Volts DC @ 175 Milliamps each or 24 Volts DC @ 100 Milliamps

Dry Contact Alarm Relays:

4 N.O. common type rated 24 Vdc @ 1 Amp. resistive.

2 Form “C” programmable rated 24 Vdc @ 1 Amp. resistive.

Dry Contact Trouble Relays:

2 N.O. common type rated 24 Vdc @ 1 Amp. resistive.

2 N.C. common type rated 24 Vdc @ 1 Amp. resistive.

Auxiliary output: Current 350 ma. Max coil resistance 14.6 ohms.

Transceiver Operating Frequency: 900 MHz band.

Signal to Noise Ratio: Minimum Signal -100.2dBm Maximum Noise -115.3dBm

Antenna Types: Omni, Yagi

Transmission Format: Frequency Hopping Spread Spectrum.

Dimensions: 17” high, 17” wide, 3 ¼” deep

Enclosure: Powder coated 16 gauge steel

Weight: 29 Lbs.

2.2 Compatibility

The following UL Listed RF devices are compatible with the CP-3000A Control Panel:

Commercial Wireless Systems International, LLC

A/C Repeater Model AR-3A – A/C powered repeater

WRA-3(R)(LG) – Remote Annunciator

Smoke Detector Model 300 – Photo Electric Smoke Detector with Integral Sounder

Smoke Detector Model 301 – Tandem Photo Electric Smoke Detector with Integral Sounder

Smoke Detector Model 302 – Photo Electric Smoke Detector without Sounder

Pull Station Model 310 – Manual Pull Station

Fire Transmitter Models 340(TS) – N.O. EOL Supervised Transmitter

CO Detector Model 350 – Carbon Monoxide Detector with Integral Sounder

The following antennas are for use with the CP-3000A:

Commercial Wireless Systems International, LLC Models:

OM-1 Omni – Isotropic gain 2.5 dBi, OM-2 Omni – Isotropic gain 1 dBi, YA-1 Yagi – Gain 15.2 dBi

The following UL Listed Digital communicator is compatible with the CP-3000A Control Panel:

Silent Knight 5104B

Notification Appliances:

As listed in the Notification Appliance Compatibility section of this manual.

Manual Service

Mount the pull station on a UL listed non-metallic junction box. Use a separate UL listed non-metallic junction box with minimum inside dimensions of (HxWxD) 5" x 3" x 2" to house the model 340(TS) transmitter. The two junction boxes shall be closed nipped together using a non-metallic conduit nipple. Wire the transmitter to the pull station N.O. contacts. Refer to the 340(TS) manuals for wiring instructions.

2.3 UL Restricted Programming Options

NOTICE TO USERS, INSTALLERS, AUTHORITIES HAVING JURISDICTION, AND OTHER INVOLVED PARTIES

This product incorporates field-programmable software. In order for the product to comply with the requirements in the Standard for Control Units and Accessories for Fire Alarm Systems, UL 864, certain programming features or options must be limited to specific values or not used at all as indicated below.

Program feature or option	Permitted in UL 864? (Y/N)	Possible settings	Settings permitted in UL 864
Aux. output activation	Y	Alarm priority A, B, C, D	Alarm Priority A
Aux. output deactivation	Y	Reset, Signal Silence	Reset
Relay Box relay deactivation	Y	Reset, Signal Silence, Smoke Detector Silence, Strobe Reset	Reset

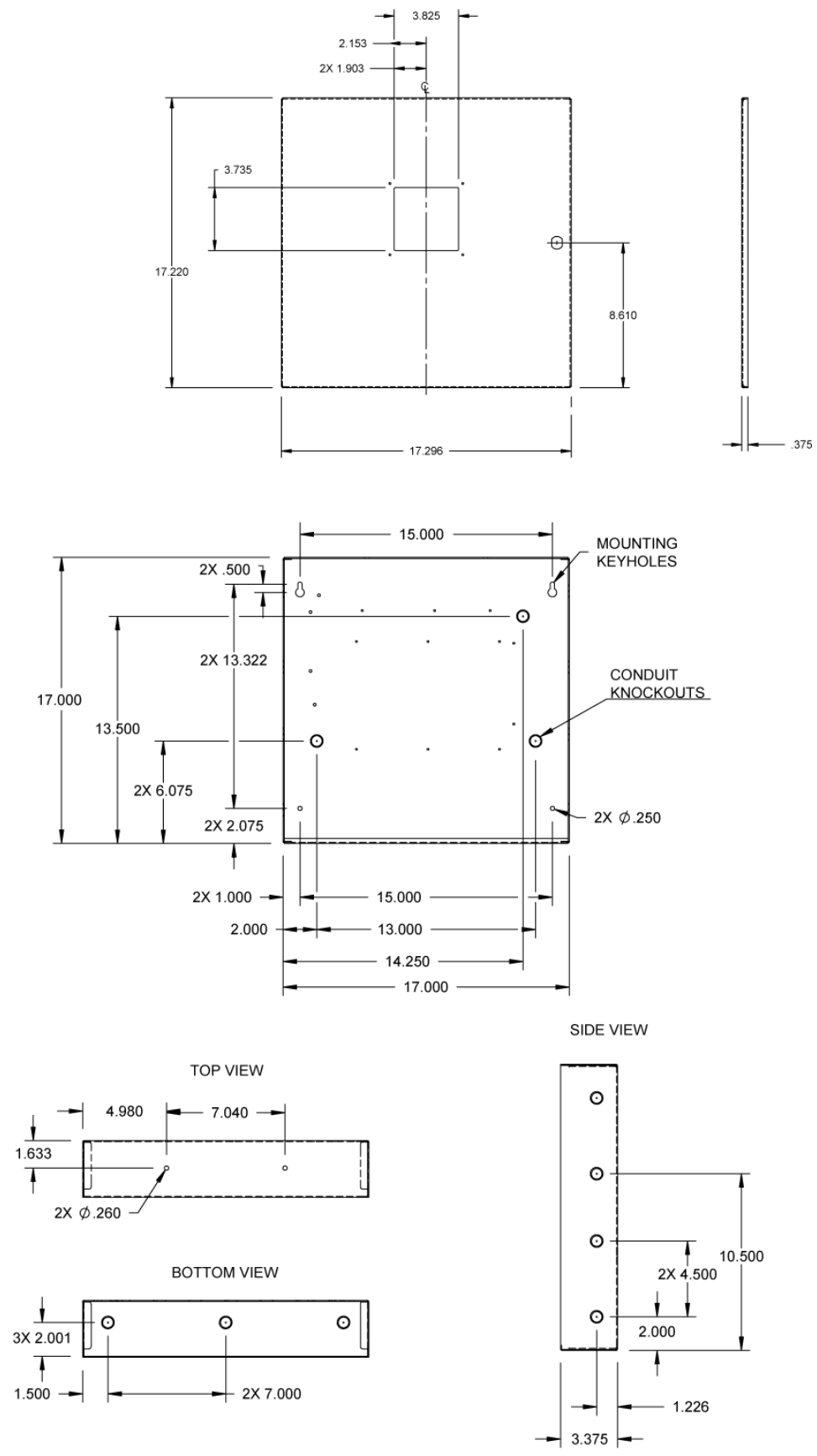

Figure 1

Section 3 - Installation

3.1 Proper Installation Order

The following steps when performed in the listed order will result in a trouble free installation:

1. Site Signal Survey
2. Control Panel Installation and Basic Programming
3. Device and Repeater Enrollment and installation
4. Control Panel Site Specific Programming
5. Entire installation test

3.2 Preparing the Installation Site

Prior to the installation of a CP-3000A system a signal survey must be performed by a factory trained technician or authorized dealer. The signal survey determines the location of the CP-3000A, repeaters, and initiating device transmitters. Refer to the Signal Survey section of this manual for the proper method to conduct a signal survey. The completed survey becomes the blueprint layout for the actual installation. When conducting a survey keep in mind the following limitations for each CP-3000A installation:

1. Maximum number of devices including repeaters is 1024. This is a limitation of the CP-3000A.
2. Maximum number of repeaters in an installation is 30. This limitation insures that the UL and NFPA 10 second alarm requirement is met.
3. Maximum number of devices per repeater or direct to the CP-3000A is 75. This is a limitation of the repeater memory. A repeater will automatically reject any devices in excess of 75 units that try to report directly to it. This is only a per repeater limitation not a system limitation.

During the survey locate A/C repeaters and CP-3000A control panel close to available 120 Vac uninterruptible power. All CP-3000A connections must be installed in conduit. When connecting primary A/C power always follow:

- 1- National Fire and Electrical Codes (NFPA 72 and NFPA 70)
- 2- Local Electrical and Fire Code requirements
- 3- Local AHJ (Authority Having Jurisdiction) requirements

WARNING: Make sure A/C supply is turned OFF prior to connecting the CP-3000A panel.

3.3 Receiving and Unpacking the Equipment

Upon receiving the equipment, the carton should be inspected for damage, which may have occurred during shipment. Each package should be checked against the packing slip for completeness. Differences should be reported to CWSI immediately. If any product is suspected of damage it should be checked for proper operation or returned to CWSI.

3.4 Installing the CP-3000A

WARNING: This equipment must be professionally installed by factory trained personnel. Use of an antenna other than listed in the compatibility section of this manual may be harmful to persons, void FCC or damage the equipment.

After conducting a signal survey the CP-3000A can be mounted in its intended location. Refer to the signal survey section of this manual for instructions on conducting a signal survey. The following should be considered and or adhered to when mounting the unit.

1 – All wiring should comply with national and/or local electrical codes. Unless otherwise specified, wire should be 18 gauge copper with 600 Volt insulation. Shielded wire is preferred.

2 – This unit is intended to be mounted in indoor dry areas. Avoid dusty, wet and corrosive locations.

3 – Provide adequate space surrounding the unit to allow for:

a - The hinged cover to be completely opened for easy access to internal components and wiring.

b - The connection of conduit to the desired cabinet locations.

c – The attachment of an omni antenna to antenna connector “A”.

4 – Avoid electrically noisy locations such as main electrical and transformer rooms, computer rooms, telephone switching rooms, etc.

Unlock the CP-3000A cover and open the unit. Carefully verify that the unit is not damaged and the printed circuit boards are properly secured and connected. Hold the CP-3000A in its intended position, verify leveling and mark the location of the upper corner mounting keyholes. Using adequate mounting screws and anchors, secure the CP-3000A to the mounting surface. Be sure to install screws in the two lower mounting holes. The conduit can now be installed into the provided knockout locations. **Power limited and non power limited wiring must be in separate conduit and kept a minimum of .25” apart in the enclosure.** Refer to *figure 4* for suggested wire routing. **WARNING: Make sure A/C supply is turned OFF prior to proceeding with A/C connection.** Connect the incoming A/C supply to the black transformer flying leads and earth ground to the gray flying lead using wire nuts provided. Required input is 120 VAC 60Hz 4 Amps. Use minimum 14 AWG 600 Volt copper wire for A/C connections. Follow all applicable electrical codes. Attach a compatible antenna to the antenna “A” SMA connector at the top of the cabinet. Antenna connector B is not used on the CP-3000A. There are three antennas available for use with the CP-3000A. The differences are the type and gain. The OM-1 Omni antenna should be used except where installation space restrictions are an issue. The OM-2 Omni will have slightly lower gain and is shorter which may be helpful in space restricted areas. The YA-1 is a directional Yagi antenna with high gain for signal reception at longer distances. Typical antenna configurations are shown in figure 1A.

To install the YA-1 follow these steps:

1. Perform a signal survey to determine an acceptable indoor location.
2. Attach the mounting brackets to a suitable surface.
3. Fasten the 24” mast to the mounting brackets and tighten the nuts.
4. Attach the YA-1 to the top of the mast and **make sure the elements are in a vertical position.**
5. Aim the antenna towards the desired reception location making sure none of the elements make contact with any surrounding surfaces or objects then tighten the antenna bracket.
6. Connect the supplied cable between the repeater and the antenna. The cable should be within the same room and not routed near electrically noisy sources such as fluorescent lights or electrical outlets.
7. Perform a signal survey after the antenna is mounted.

Typical Antenna Configurations

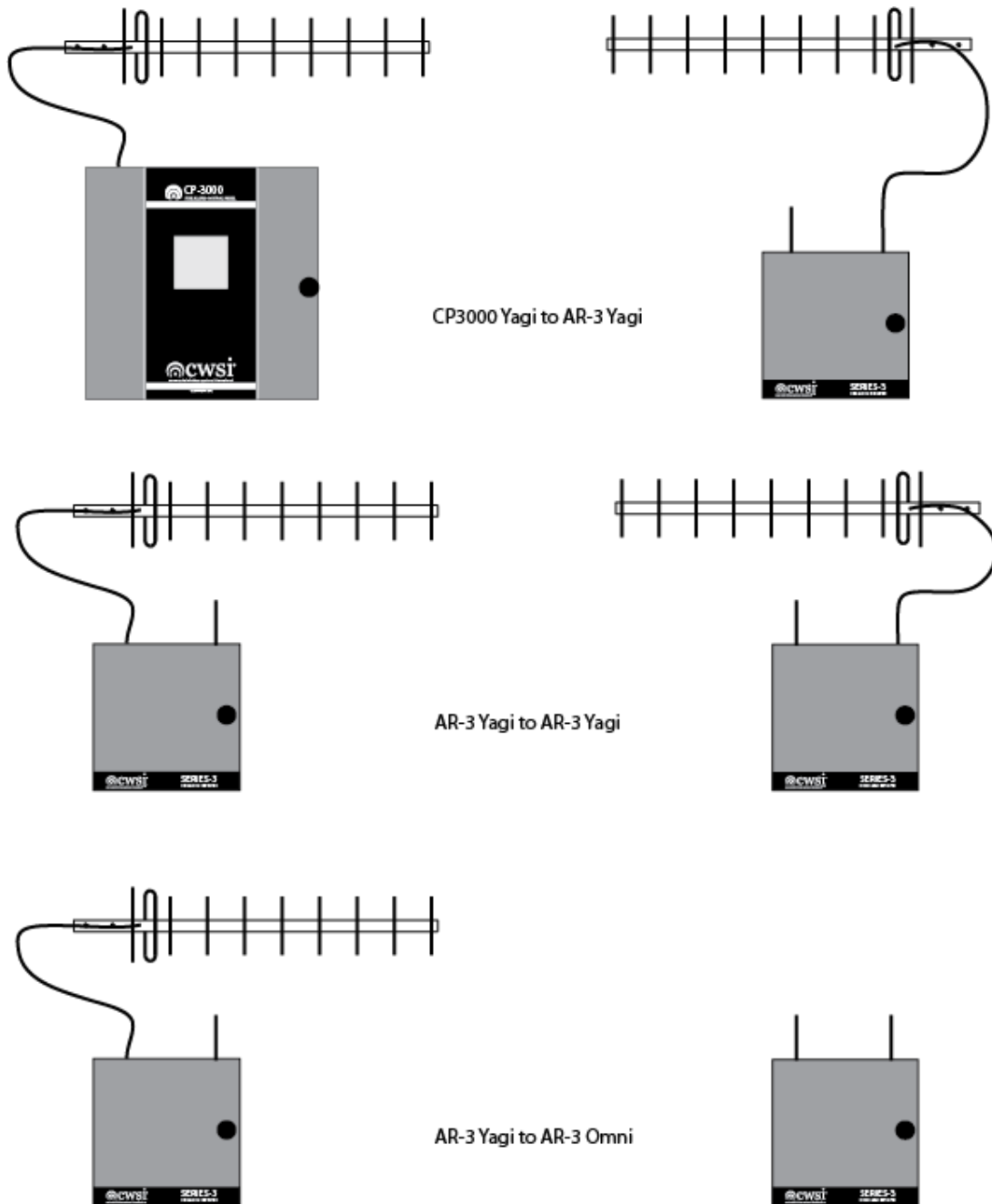
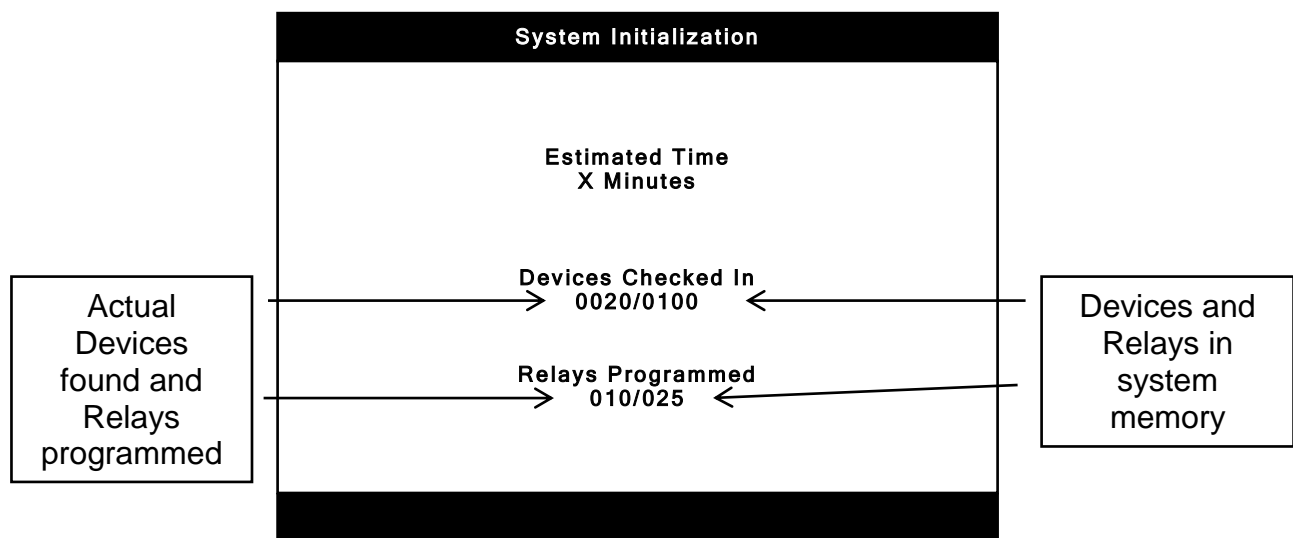

Figure 1A

Always perform the signal survey with the antenna that will be used on the repeater when it is installed. It is recommended to not connect any other equipment such as horns or communicators to the CP-3000A until the unit is programmed. There is a 6 position dip switch marked SW2 located on the receiver card. Verify that all of the switches are in the on position. Any other settings of this switch will result in improper operation of the CP-3000A panel. Now apply A/C power and connect charged

batteries as shown in figure 4. A short beep may be heard from the receiver piezo sounder. This is normal. The LCD will show the CWSI logo and will begin to boot up. When the CP-3000A has finished the boot up process the System Initialization screen will be shown on the LCD. **Note: If there is a communication problem between the receiver pc board and the CP-3000A main board the LCD will not display the initialization screen. Instead a message that the receiver board was not found will be shown. If this message appears, power down the CP-3000A and check the settings of SW2 on the repeater board and proper connection of the wiring harness between the receiver and CP-3000A main pc board. Reapply power and if the receiver notice is displayed again, the unit must be returned to the factory.** While the initialization screen is displayed the system will attempt to communicate with any enrolled devices, annunciators and repeaters that are in the CP-3000A memory. The CP-3000A will also verify and or update any relay programming for the repeaters according to the current CP-3000A programming memory. An estimated time is shown to complete the system initialization. The time shown is approximate and will vary based on the amount of devices and relays to be found and verified. The initialization process could take an hour on a system with many devices and programmed relays. Keep in mind that the CP-3000A system initialization only occurs once when the panel is powered up. The process cannot be aborted and must be completed prior to letting the user continue with further programming and system operation. There are two sets of numbers displayed on the screen. Each set is divided by a /. One set appears under the Devices Checked in header and the other under the Relays Programmed header. The number to the right indicates a count of the devices and relays currently in the CP-3000A memory. The number on the left will increment as devices and relays are found and programmed. The initialization process will end when either the CP-3000A finds all of the devices and programs all of the relays in memory or the estimated time is exceeded without finding all of the devices and or programming all of the relays. Any unfound devices when the initialization process is complete will be shown as a test failure trouble. The receiver board in the CP-3000A counts as a repeater therefore the number shown for the devices in the system memory will always show at least 0001 even if no devices or repeaters have been enrolled. After the system initialization is completed the System Requires Configuration screen will be shown. Refer to the system programming section of this manual to complete the initial configuration.

System Initialization Sample Screen



3.4.1 Enrolling Devices, annunciators and repeaters

Warning: All initiating devices, annunciators and repeaters must be enrolled into the CP-3000A control panel. Initiating devices, annunciators and repeaters will not report alarms or troubles until they are enrolled. Do not install batteries in any device or apply power to any repeater or annunciator until the CP-3000A is in enrollment mode. Device enrollment allows the CP-3000A to accept signals from that device. It also programs the base code into the device and stores the serial number into the CP-3000A memory. The main system normal screen must be showing before the CP-3000A can be placed into enrollment mode. If any alarms or troubles are showing on the LCD, reset the CP-3000A to gain access to the PROGRAM soft key. While the main screen is showing, press the program soft key to display the program menu selections. If necessary, use the UP/DOWN keys to highlight DEVICE ENROLLMENT then press the ENTER key to place the CP-3000A in enrollment mode. The following screen will appear.

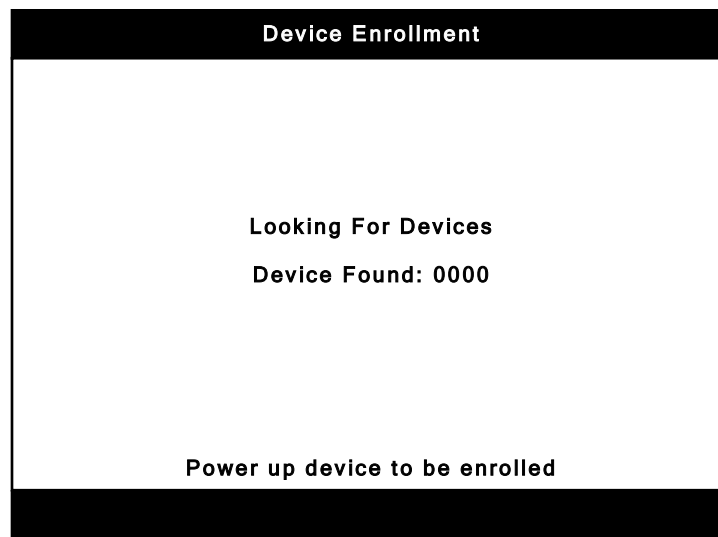

Note: The CP-3000A will remain in enrollment mode indefinitely until the BACK key is pressed or an alarm is received. A trouble will not cause the system to exit enrollment mode.

Devices, annunciators and repeaters can be enrolled anywhere in the installation provided the device being enrolled is within RF reception range of any enrolled repeater or the CP-3000A panel. Keep in mind that you can only enroll a maximum of 75 devices to any one repeater or direct to the CP-3000A. To enroll a device, annunciator or repeater simply install the battery or for a repeater, connect either battery or a/c power. The unit being enrolled will beep twice indicating it has established communication with a repeater. **It can take up to 30 seconds for the two beeps and enrollment to occur. If the unit does not enroll or the two beeps are not heard within 30 seconds, remove and reapply power to the unit being enrolled.**

The following are reasons why a unit will not enroll:

- 1. The CP-3000A is not in enrollment mode. Place the CP-3000A in enrollment mode.**
- 2. The unit being enrolled is not within RF range of an enrolled repeater or the CP-3000A panel. Make sure it is in reception range of a repeater or the CP-3000A.**
- 3. The unit being enrolled already has a base code programmed in it. Clear the base code from the unit. Refer to the individual device manual for instructions on how to clear the base code.**

The screen below will be present on the LCD when a unit has been enrolled. The Devices Found counter will increment as each unit is enrolled. There are also two sets of six digit numbers/letters separated by a dash. These indicate the serial numbers of the unit being enrolled and the repeater it has established communication with. The serial number to the left of the dash is the unit being enrolled and the one to the right of the dash indicates the repeater it has established communication with.

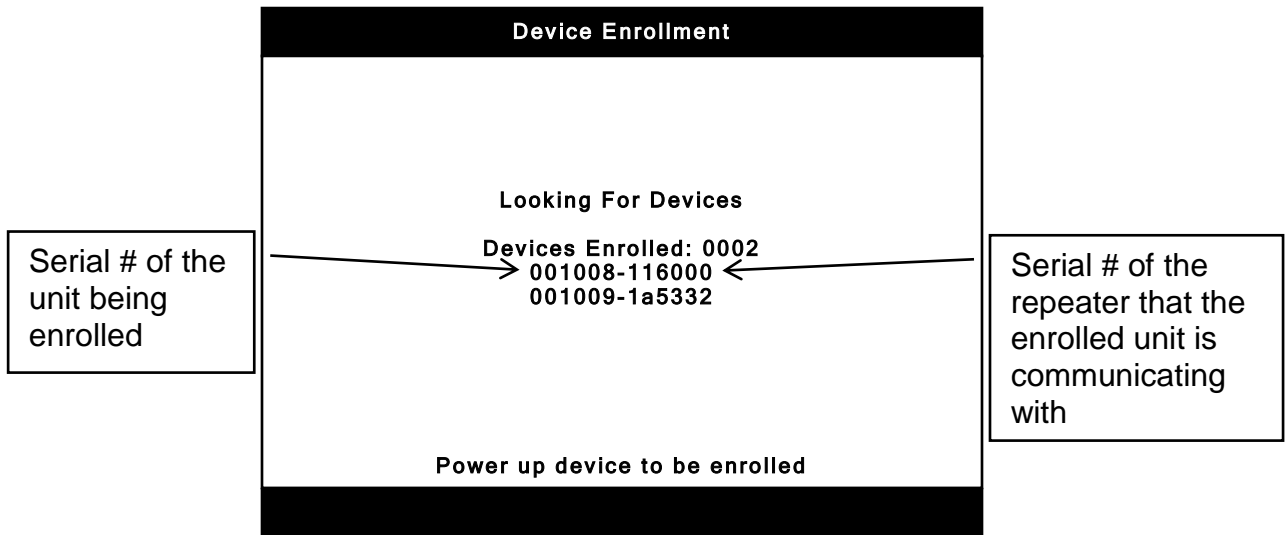

If the number of enrolled devices exceeds the display limitation of one page on the LCD, page up and page down soft keys will appear to allow the additional enrolled devices to be viewed. **It is highly recommended that you write down the serial numbers of devices, annunciators and repeaters as you enroll them so you can verify them against the LCD display to make sure all of them have been enrolled.** The Devices Found count should also match the number of total units enrolled. After the devices, annunciators and repeaters are enrolled they can be installed as outlined in the next section. It is acceptable to enroll and install each device one by one rather than enrolling all the devices then installing them. If you use this method, the CP-3000A has to remain in enrollment mode during installation and the devices will have to be tested for alarm operation after enrollment and installation of all the devices, annunciators and repeaters is completed.

3.4.2 Installing the Annunciators, Repeaters and Initiating Devices

Warning: All devices, annunciators and repeaters must be enrolled as described in the previous section prior to installing them. This section assumes the devices, annunciators and repeaters have already been enrolled to the CP-3000A. After enrolling the devices the next step is to mount the initiating devices, annunciators and repeaters at their locations. **Important: As you install each device and repeater make a list of their serial numbers along with a description of the mounting location. This information is necessary so it can be entered into the description field for each device and repeater.** During installation the CP-3000A can be placed in test mode or left in normal operation. Placing the panel into test mode will abort any NAC circuits and CP-3000A alarm outputs from activating. Leaving the CP-3000A in normal operating mode will allow all NAC circuits and alarm functions to operate normally. The devices intended to directly communicate with the CP-3000A should be installed first. Insert the battery in the device then hold the device at its desired position and generate a signal survey transmission from it. Refer to the individual device manual and

the signal survey section of this manual for signal survey instructions. If the signal is acceptable the device may be installed at that location. Slight transmitter location or orientation adjustments may have to be made in order to obtain acceptable signal strength results. Do not mount any device unless acceptable signal strength indicating tone is heard from the sounder in the device being tested. Once the device is mounted confirm acceptable signal strength once more to insure proper operation. After the device has been installed and signal verified, activate the device for an alarm signal transmission and verify proper alarm reception and proper site specific programming operations. Next proceed with the first repeater location closest to the CP-3000A panel. Temporarily connect the backup batteries to power the repeater, hold it in its intended mounting location and perform a signal survey test. If the test result is acceptable, install the repeater in accordance with its instruction manual and perform a signal survey test after permanently mounting the repeater. Then install the devices that report to that repeater verifying acceptable signal survey results for each device as previously described. Continue out from the panel installing the balance of the repeaters and devices until the installation is complete. It is recommended that notification appliances and repeaters be installed at the same time. Refer to the repeater manual for a list of notification appliances and other equipment approved for connection to a repeater. Any equipment to be connected to the CP-3000A such as dialers, notification appliances etc. can be installed and connected before or after installing the initiating devices. Refer to other sections of this manual for compatible equipment. Be sure to attach the cover panel as described in section 3.4.4. After all of the equipment has been installed and powered up be sure to reset the panel back to normal operation mode. Various troubles may be reported while installing the devices, annunciators and repeaters. This is normal. After all of the equipment is installed reset the panel. If any troubles exist they will be reported within 200 seconds. Refer to the operation section of this manual for further information. The CP-3000A should now be programmed for site specific functions required in the installation. A full system test must be performed after programming the CP-3000A and all of the devices, annunciators and repeaters have been installed. The system test should include initiating an alarm from all devices and verifying proper NAC activation as well as central station communication if applicable.

3.4.3 The Backup Batteries

The cabinet houses two 12 Volt lead acid batteries wired in series for a total of 24 volts dc. Use only Genesis/Energys batteries P/N NP4-12 for 24 hours of backup time and NP7-12 for 60 hours of backup time. Install the appropriate batteries and wire as shown in figure 4 on page 41 using the supplied battery harness. The battery harness connector plugs into J2 on receiver card. The black wire should be on the left and the red wire on the right when it is connected properly. We recommend replacing the batteries in accordance with NFPA 72 guidelines or every three years. After replacing the batteries install the cover panel as described below.

3.4.4 Cover Panel

The cover panel attaches to the inside of the cabinet with 6 screws. It protects the user from coming in contact with the electronics but still allows full access to all control panel operation switches. The cover panel must be installed. Figure 2 illustrates panel location and attachment. When installing the cover panel make sure the backup batteries are not located behind any of the 3 lower cover panel attaching screws or battery damage may result. If any resistance is felt when attaching these screws, stop and check the location of the batteries.

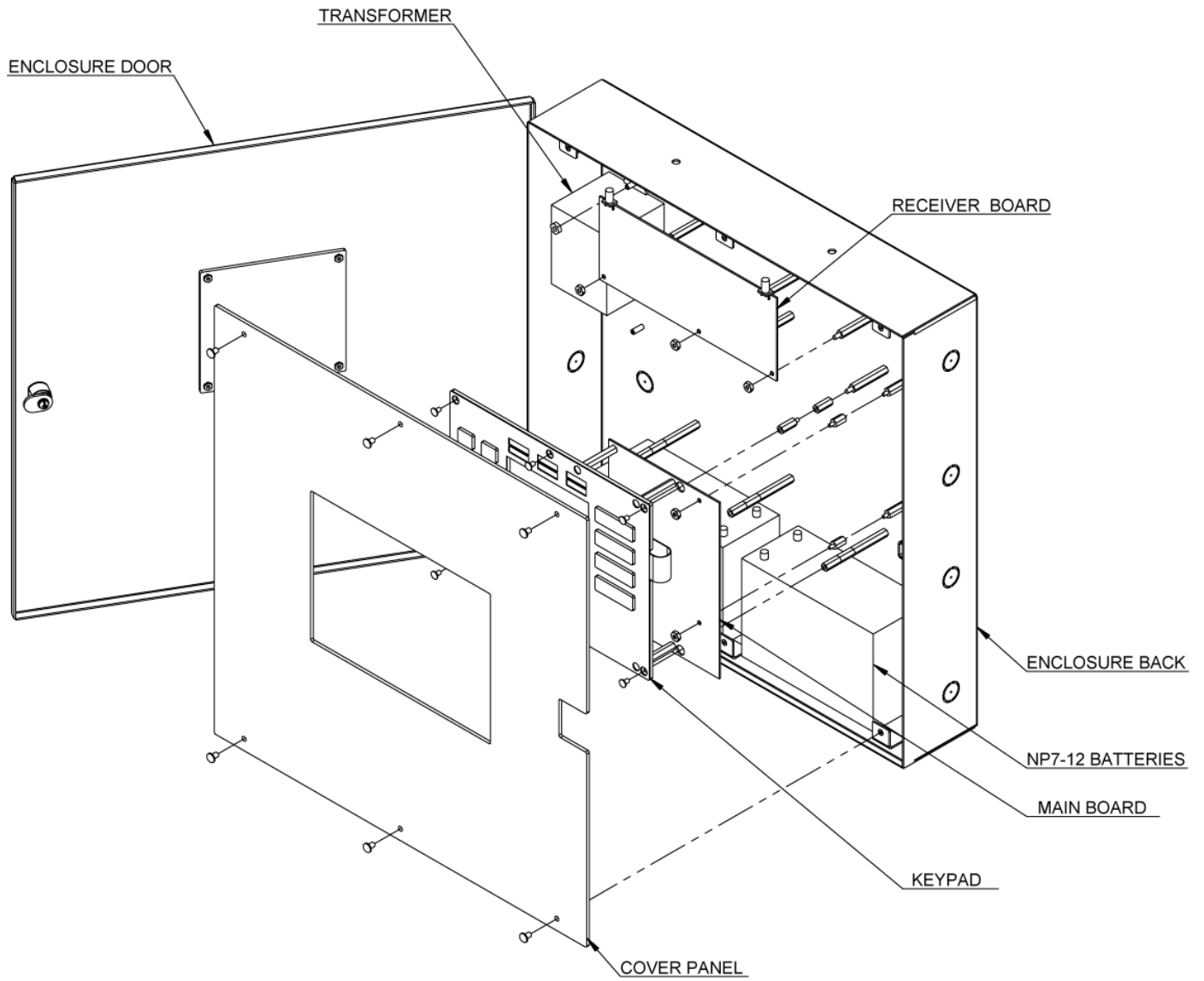

Figure 2

Section 4 - System Programming

This section details system programming options including time/date, password, base code, device enrollment, NAC/Auxiliary/Relay activation and resetting, tandem smoke detector activation and deactivation, device editing and zone assignment.

4.1 Keypad Buttons and Menu Navigation

The buttons located in the area below the LCD are used for menu navigation and data entry. These include 4 Softkey, Up/Down/Left/Right, Enter and Back buttons. See figure 3 below for the location of these buttons. The Up/Down/Left/Right buttons are used for menu navigation and character/number selection. The Enter button is for selecting and unselecting data entry fields. The Back button takes you one menu level back from the currently displayed menu. The softkeys are located directly under the LCD and are the arrowed buttons pointing up at the LCD screen. The softkeys perform multiple functions and will change as needed for the particular programming being performed. The softkey functions are displayed on the highlighted bottom line of the LCD just above these buttons. This manual will refer to the softkeys as numbers 1-4 from left to right.

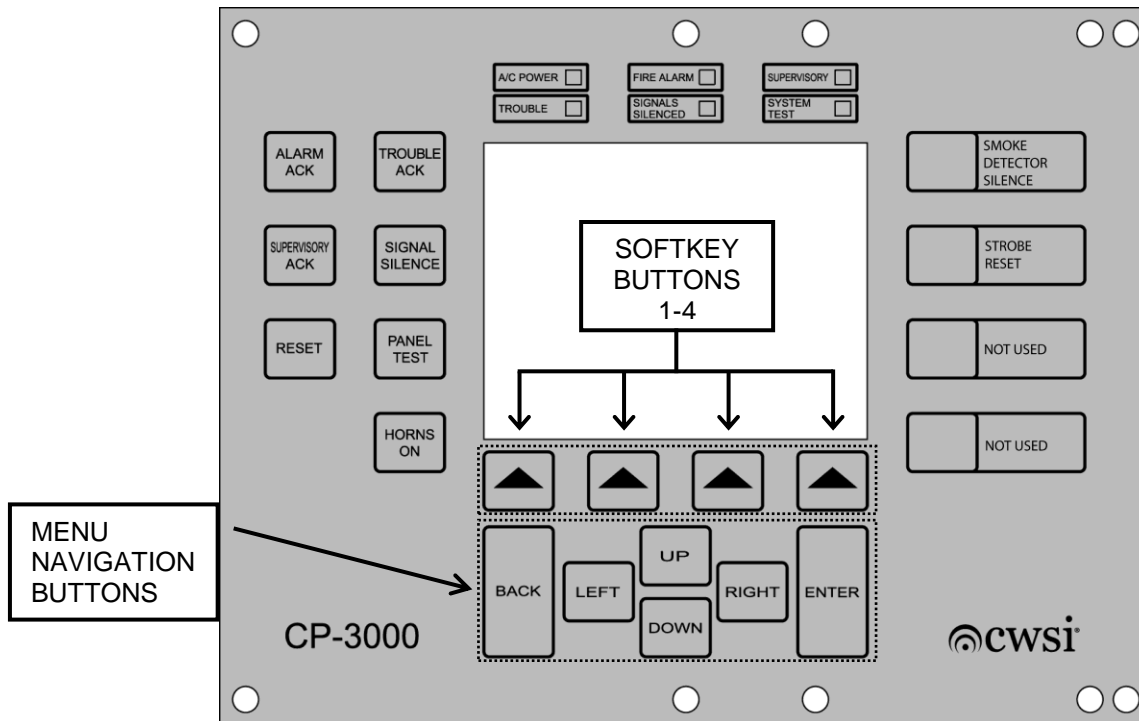

Figure 3

4.2 Menu Selection and Navigation

4.2.1 Menu Basics

The CP-3000A menus can only be accessed if the main system normal screen below is showing on the LCD. Menu access is not allowed if any Alarm, Supervisory or Trouble signals are present on the LCD. These conditions must be reset so the main screen is showing before any menu selections will appear. When any menu is chosen a 3 minute timer will start. If any menu activity such as navigation or field editing is not performed within 3 minutes the CP-3000A will revert back to the main screen and any unsaved changes will be lost. If an Alarm or Supervisory signal is received while in any menu the CP-3000A will abort the menu/programming functions and display the Alarm or Supervisory condition on the LCD and any unsaved programming information will be lost. If a Trouble signal is received it will not abort the menu/programming functions. All other trouble indications will occur except displaying the trouble. When the user exits all menus the trouble condition will be displayed.

CP-3000A Main Screen

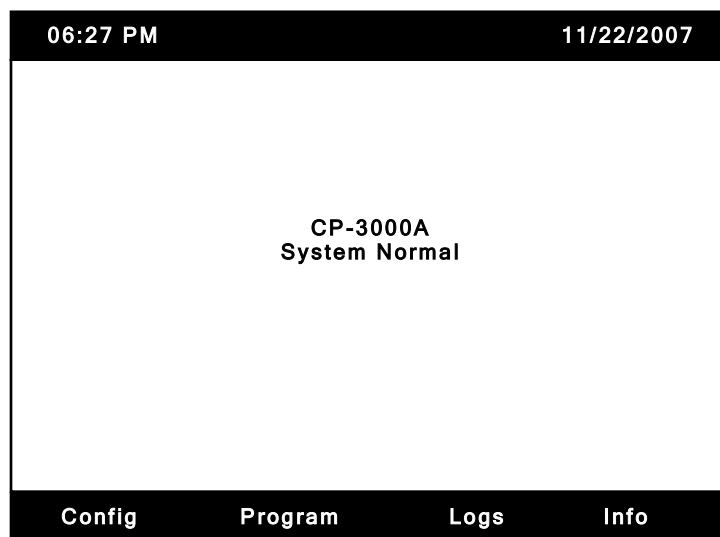

4.2.2 Menu Selections

The following flow charts outline the main menu selections and associated sub menus. Refer to this section to locate a particular menu when it is referenced in this manual.

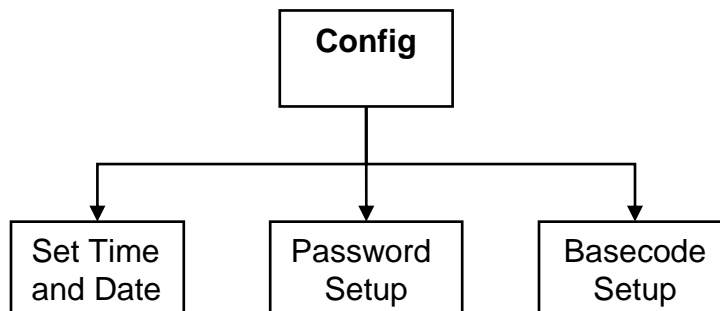

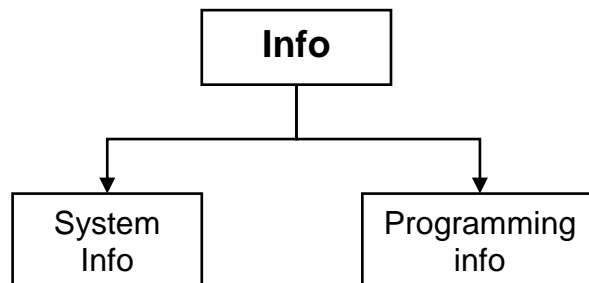
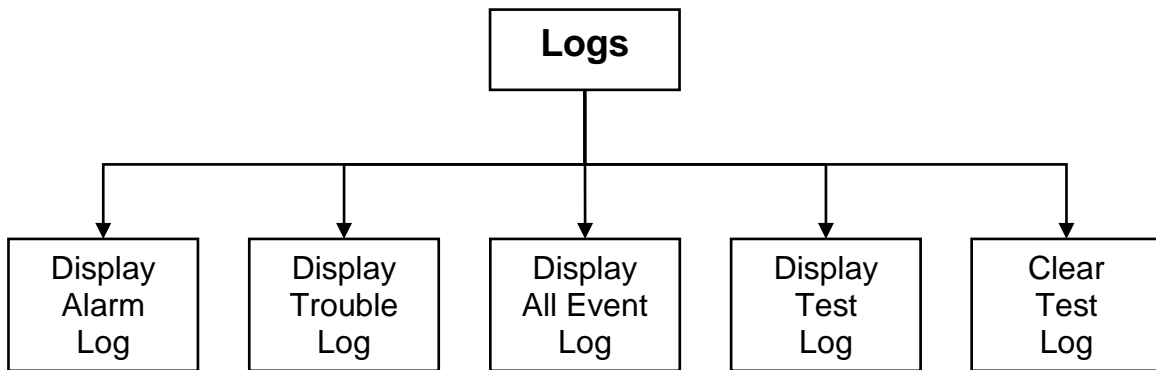
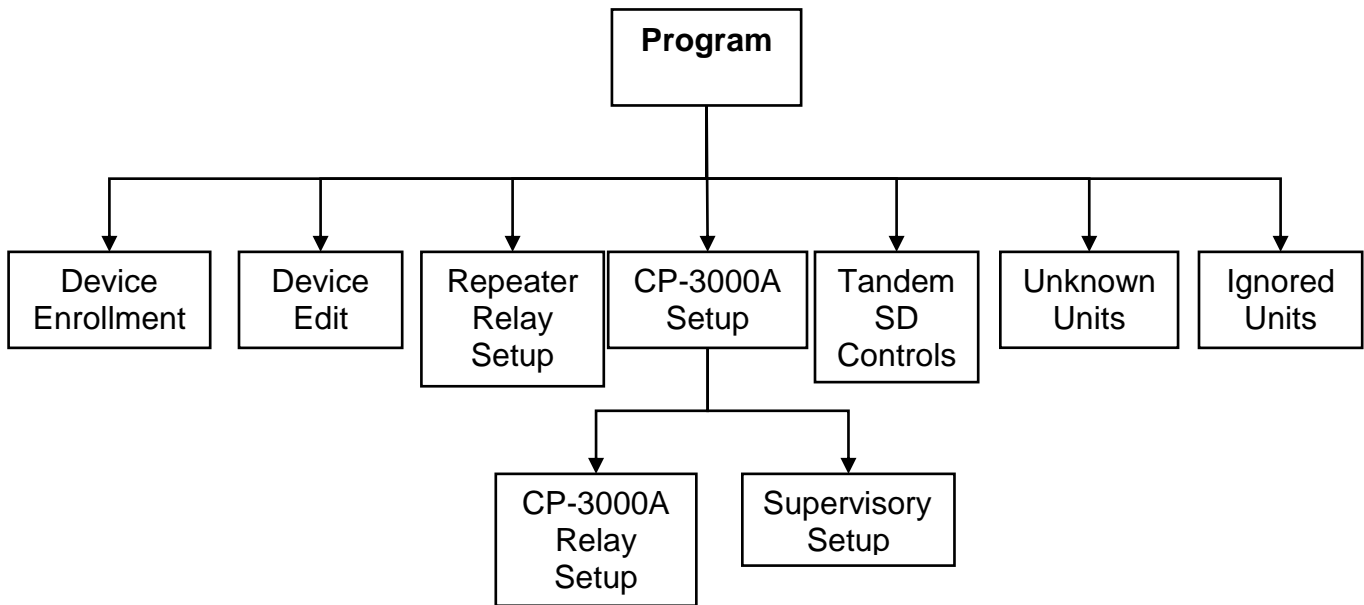

4.2.3 Menu Access, Navigation, Data Entry and Field Editing

When any of the soft key buttons are pressed to gain menu access you will be prompted to enter a password. The password entry screen is shown below.

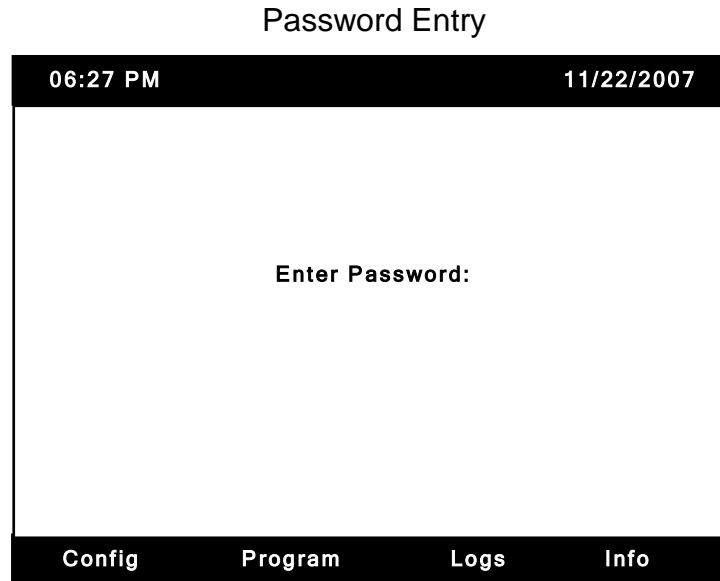

The cursor will be blinking in the password entry field under the first character to be entered. Use the UP/DOWN keys to select the first number in the code. There are ten choices 0-9. **The default password is 3000** so the first character is 3. After the number 3 is showing in the first digit, press the RIGHT key to move the cursor to the next position then UP/DOWN to select the second character and so on until all four numbers are showing. Press the ENTER key when the correct password is showing and you will have access to the menus. If ENTER is pressed with any of the wrong characters showing or 4 numbers are not entered, the field will clear and the entire password will have to be entered again. When a correct password is entered a ten minute timer will start allowing menu access without reentering the password. You will only have to enter the password again if ten minutes elapses without any programming menu activity.

Once the correct password is entered the menu choices are displayed. Use the UP/DOWN keys to move the highlighted box. When the desired menu is highlighted press the ENTER key and that menu choice will be selected. Pressing the BACK key will take you one menu level back.

When you have accessed a programming screen that has data fields which can be edited, a blinking cursor will be present under the first field. Press the ENTER key to edit the field or use the UP/DOWN keys to move the cursor so it is under the field you want to edit then press the ENTER key. The field being edited will be highlighted.

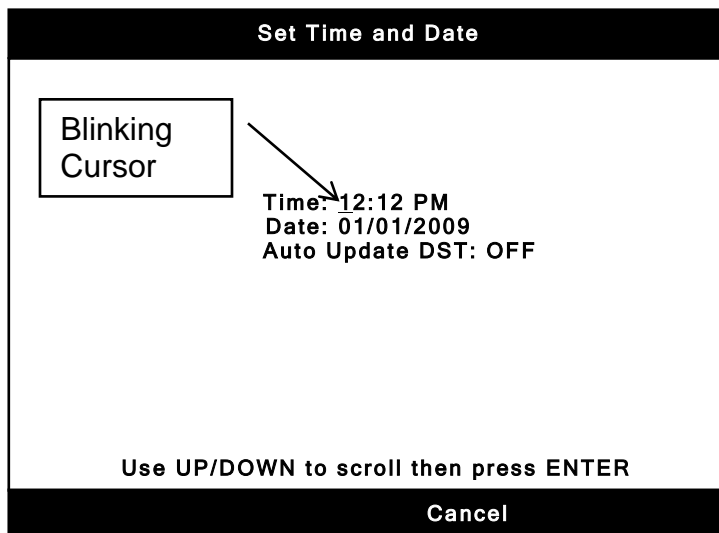

Press the ENTER key and the field can be edited.

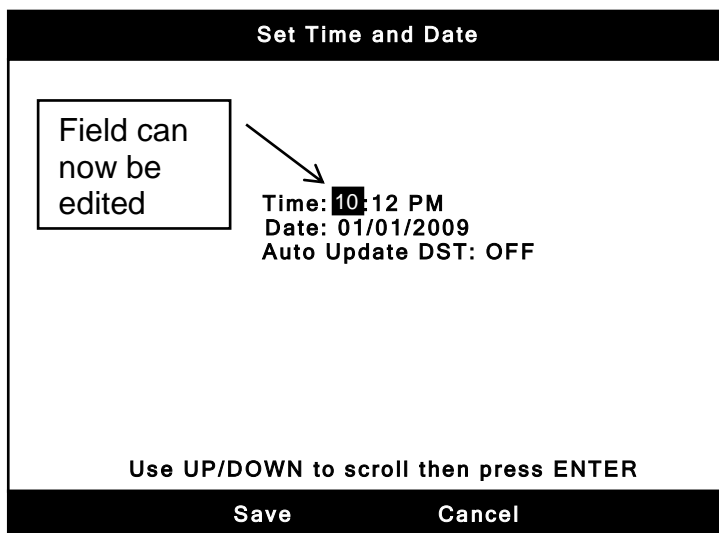

Some fields such as descriptions will require pressing the LEFT/RIGHT keys in order to change each character within the field. After you are finished editing the field press the ENTER key to exit edit mode. The field will revert back to normal and will not be highlighted anymore. Move the cursor to the next field to be edited and press the ENTER key to highlight that field and changes can be made. When any field on the page has been changed a soft key will appear with the word SAVE above it. Press this soft key to save the changes or CANCEL to abort all changes to the page. If you press the BACK key without saving a screen will appear asking if you want to save. Press the appropriate soft key and you will exit the screen and be taken one menu level back. **If you do not SAVE your changes, all of the fields that have been edited on that page will be lost.** When you enter any menu screen a timer will start. If there is no key press activity for three minutes, the CP-3000A will revert back to the system normal screen and any unsaved changes will be lost. Save your changes often. These rules for menu navigation and field editing apply to all of the programming screens.

4.3 Initial System Configuration

After the CP-3000A is powered up and the automatic System Initialization procedure is complete the System Requires Configuration screen will be shown.

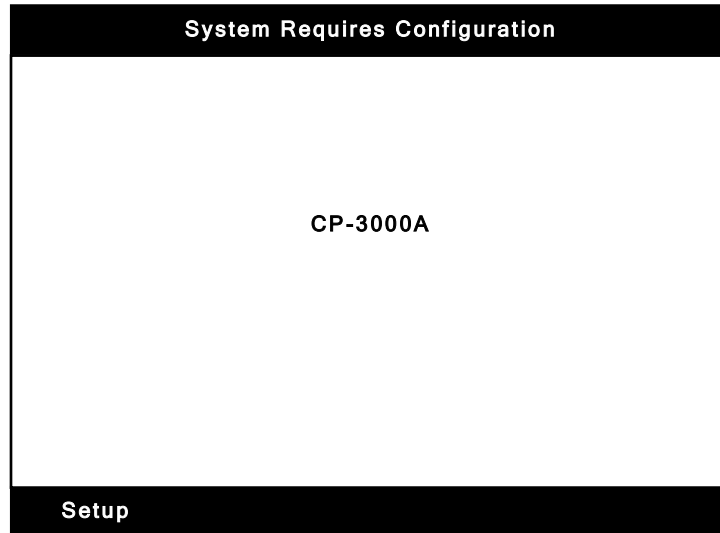

Press the setup soft key and you will be prompted to enter a password. The default password is 3000. After entering the password press the ENTER key and the screen below will be shown.

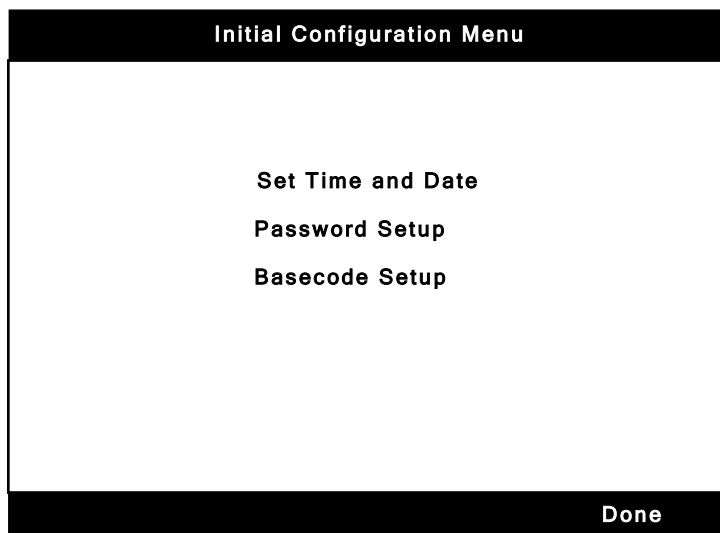

The three menu items shown are important to verify and change if necessary before continuing to the system main screen and performing any other programming. **We strongly recommend setting the time and date as a minimum so the event logs will have the correct time and date from this point forward.** If you choose not to change or set any of these items then you can press the DONE soft key to proceed to the main CP-3000A screen. All of these items can be changed later through the Config menu accessible from the main screen.

4.3.1 Set Time and Date

To set the time and date press the ENTER key while the set time and date menu choice is highlighted. The set time and date screen below will be shown.



Set Time and Date

Time: 03:00 PM

Date: 01/01/2009

Auto Update DST: ON

Cancel

The blinking cursor will appear under the hour in the time field. Follow the instructions in section 4.2.3 for field editing and make the necessary changes to adjust the clock to the proper time. The hour, minutes and AM/PM settings are considered one field so after you highlight and set the hour use the RIGHT button to highlight the minutes field. After the minute is set use the RIGHT key to move to the AM/PM field and set it. When you have time correctly set press the ENTER key to stop edit mode. Use the same procedure to set the date and the Auto Update DST setting. When the DST is off the clock will not be updated automatically for daylight savings time. If DST is on the clock will be automatically adjusted for daylight saving time. The DST time changes are in accordance to government parameters as of JULY 2009. After making the desired changes press the SAVE soft key to save the new settings and display the Initial Configuration Menu. Pressing CANCEL will abort any changes and display the Initial Configuration Menu screen.

4.3.2 Password Reset

To change the password highlight the Password Setup menu choice on the Initial Configuration Menu screen and press ENTER. The screen below will be shown. The default password is 3000.



Password Reset

Enter Old Password:

Enter New Password:

Cancel

The Enter Old Password field will be highlighted and the blinking cursor will be under the first digit. Enter the current password using the UP/DOWN and LEFT/RIGHT buttons. When the current password is showing press the ENTER button and the Enter New Password field will now be highlighted. Enter the new password and press the ENTER button to exit edit mode. Press the Cancel soft key to abort the changes or the Save soft key to save the new password. You will be taken back to the Initial Configuration Menu.

4.3.3 Base code Setup

The base code is the code that the enrolled devices use to know what CP-3000A they are reporting to. When the CP-3000A is powered up it randomly chooses one of 252 random base codes to use. In an installation where more than one CP-3000A is required, it is **mandatory** that the base codes be different on each one so the devices will know which CP-3000A to report to. This is true where any device, repeater or CP-3000A in one installation is in reception range of any device, repeater or CP-3000A in the same or a different installation. **Warning: You must verify that each CP-3000A in reception range of another has different base codes before enrolling any devices or repeaters. If you change the base code after enrolling the devices then every enrolled device will have to be deleted, have their base code cleared and then be enrolled again.**

To look at the assigned base code and change it if necessary, highlight the Base code Setup menu choice and press ENTER. The screen below will be shown.

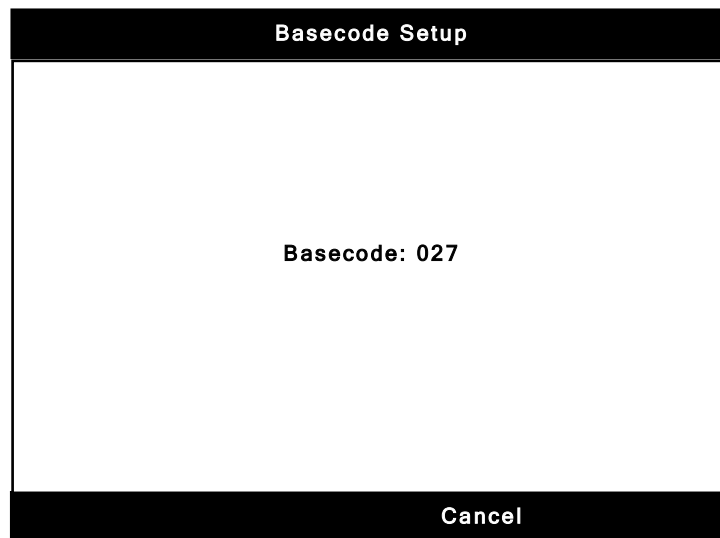

To change the base code, press ENTER. The base code choices are 002 to 252. Base codes 000 and 001 are reserved for system use. Use the UP/DOWN buttons to choose the first digit in the code then move the cursor to the second digit using the RIGHT button. Now enter the third digit the same way. When the desired base code is displayed press the ENTER button to exit edit mode. **We strongly recommend you do not change the base code unless absolutely necessary. Only change it before enrolling any devices or repeaters. Changing it when devices, annunciators and repeaters are enrolled will cause all enrolled devices, annunciators and repeaters to show test failure.** When you are done making the desired changes press the Save soft key to save the change and display the Initial Configuration Menu.

This completes initial configuration of the system. Press the DONE soft key to go to the CP-3000A main screen. **Note: If any alarms or troubles are in process the main screen will not be shown after pressing DONE. The in process alarms or troubles will be shown instead.**

The Time and Date, Password and Base code can be modified anytime after the initial configuration by pressing the Config soft key while the main system 3000 ok screen is displayed.

4.4 Device, Annunciator, Repeater and CP3000A Info Programming

This section describes how to input zone assignment, alarm priority, device type and description information for devices, annunciators and repeaters. Entering this information is crucial for proper activation of notification appliances etc. as well as notifying responding authorities of the precise location of an alarm in process.

4.4.1 Accessing the Device Edit screen

To begin entering device and repeater information you must access the Device Edit screen. While the main system normal screen is showing press the soft key labeled program. Enter the correct password if required. The programming menu choices will be displayed. Using the UP/DOWN keys, highlight the Device Edit menu choice and press the ENTER key. A screen similar to the one below will be displayed. **Note: Changing and saving any field in a device annunciator or repeater edit screen will cause a checksum bad trouble on all installed annunciators. To correct this trouble update the programming in all installed annunciators as described in the WRA-3 manual.**

The screenshot shows a screen titled "Select Device to Edit". It contains a list of devices with their serial numbers and descriptions. The first device is highlighted with a black bar. To the right of each device name is the text "*NEW UNIT*". At the bottom of the screen, there is a prompt "Use UP DOWN to scroll then press ENTER" and a "Delete" button.

Serial Number	Description	Status
03a492	Pull Station	*NEW UNIT*
005c28	REPEATER	*NEW UNIT*
04b530	Smoke Detector	*NEW UNIT*
680017	Annunciator	*NEW UNIT*

Use UP DOWN to scroll then press ENTER

Delete

Any devices or repeaters that have not been previously edited will show the NEW DEVICE text in the description field. Use the UP/DOWN keys to highlight the device, annunciator or repeater you want to edit and press the ENTER key. The screen below will be shown when a device is edited. Note: The first time a device is edited, the title on this screen will read New Device Setup. The serial number is fixed and cannot be edited.

Edit Device		
Serial #	:	03a492
Zone	:	000 000 000
Alarm Priority	:	A
Device Type	:	Pull Station
Description	:	
Total Devices Registered: 0002		
ALPHA	Number	Symbol

When a repeater or annunciator is edited, only the serial number, device type and description are shown. The description is the only editable field for a repeater or annunciator. Zone and alarm priority information do not apply. A sample repeater edit screen is shown below. Note: The first time a repeater is edited, the title on this screen will read New Repeater Setup. For annunciator screens substitute the word annunciator for repeater in the following examples.

Edit Repeater		
Serial #	:	03a492
Device Type	:	Repeater
Description	:	
Total Repeaters Registered: 0001		
ALPHA	Number	Symbol

The same field editing rules apply here as described in section 4.2.3. Move the cursor to the desired field and press ENTER. When done editing press ENTER again to exit edit mode. When a field has been modified, the word save will appear above the #4 soft key. Save after you have made all of the desired changes as pressing the save button will back you out to the Select Device to be Edited screen. If you press the BACK key without saving a save confirmation screen will appear. Make the appropriate selection when prompted.

4.4.2 Deleting a Device, annunciator or repeater

To delete a device, annunciator or repeater from the system:

1. Locate the Device(s) and/or Repeater(s) you want to delete and remove all power from it.
2. Allow the powered down units in step 1 to show a test failure trouble.
3. Reset the CP-3000A and access the device edit list through the device edit menu choice.
4. Use the UP/DOWN keys to select the device(s) and/or repeater(s) to be deleted and press enter.

Warning: The CP-3000A will no longer accept alarms or troubles from deleted devices or repeaters. To get a deleted device, annunciator or repeater to report to the CP-3000A again you must enroll it. You must remove all power from a device, annunciator or repeater and allow it to show a test failure trouble on the CP-3000A before deleting it. Failure to remove power and allow the device, annunciator or repeater to show a test failure trouble prior to deleting may cause an unknown device trouble on the CP-3000A. Refer to the section on unknown and ignored devices for more information. When a repeater is deleted, you will be prompted with a warning telling you that the repeater will be permanently disabled until its power is removed and reapplied. Answer yes to continue with deleting the repeater. The repeater will be sent a command from the CP-3000A telling it to shut down its transceivers. This is only a safe guard in case the deleted repeater is not powered down prior to deleting it. It is possible that one or more of the deleted repeaters may not receive the turn off command if a repeater was deleted which was required to link the turn off command to other deleted repeaters. Any deleted repeater which does not receive the turn off command will stay active and will allow devices and other repeaters to link to it causing those devices, annunciators and repeaters to show a test failure trouble on the system. **Always remove all power to a device, annunciator or repeater and allow it to show a test failure trouble on the CP-3000A before deleting it. Note: Deleting a device, annunciator or repeater will cause a checksum bad trouble on the CP-3000A. Refer to the WRA-3 manual for information on clearing a checksum bad trouble.**

4.4.3 Device Zone Assignment

Use of zone assignment to section areas of an installation is common practice in the fire alarm industry. It offers flexibility to assign devices to activate NAC and other outputs as needed in the installation or required by local authorities. The CP-3000A has 999 available for use. These will be entered as 001-999. Zones only need to be entered in installations which require NAC, RB relays or model 301 tandems smoke detectors to activate. Simple annunciation only installations do not require zone programming. Refer to section 4.8 for model 301 zone programming instructions.

The zones are split into two groups, 001-899 and 900-999. The first zone group 001-899 applies to alarms and the second zone group 900-999 applies to troubles. The alarm zones 001-899 are used to activate repeater NAC's, RB series relay box relays or model 301 tandem smoke detectors when an alarm is initiated from a device. The trouble zones 900-999 are used to activate repeater NAC's or RB series relay box relays when any trouble condition is transmitted from that particular transmitter programmed with the trouble zones. Zones cannot be assigned to annunciators.

In order to activate NAC's or relay box relays, zones also need to be programmed into the repeater. Refer to the section on repeater NAC/relay programming for instructions on how to program zones into a repeater. When a device with a programmed zone initiates an alarm or trouble and that device zone matches any zone programmed into a repeaters NAC's or relays that output will activate. Keep in mind that each device and repeater output can be programmed with up to 3 zones each. This method of programming allows virtually any installation requirement to be met.

To assign zones to a device access the edit screen for the desired device as described in the previous section. Move the cursor to the first digit in the zone field and press ENTER. The three characters for the first zone will be highlighted. Use the UP/DOWN and LEFT/RIGHT keys to select each number and move between digits of the first zone. The three zones are separate fields so to move to the second and third zones press ENTER to exit edit mode and use the LEFT/RIGHT keys to move the cursor to the next zone entry field. Press ENTER to highlight it and edit as needed. When all of the zones have been entered as desired, press the ENTER key to exit the edit mode. The zone field will now be unselected. Don't forget to save your information.

Important: Only devices within the same zone can reactivate silenced NAC outputs in that zone. Therefore if you require all of the devices to reactivate any silenced NAC outputs then all of the devices and NAC outputs must be on the same zone. This is primarily a decision to be made by the AHJ as it may be permissible to have physically separated zones not reactivate each other after being silenced. Consult with the AHJ for approval.

4.4.4 Alarm Priority Assignment

The CP-3000A has 4 levels of alarm which can be assigned to devices. These alarm levels are referred to as A, B, C and D. A is the highest priority and D is the lowest. Level C can be used for either Supervisory or fire applications but not both. The CP-3000A will display signals based on priority. Refer to the operation section of this manual for more information.

To program an alarm priority to a device, access the edit screen for the device to be programmed. Move the cursor to the alarm priority field and press ENTER to edit the field. Use the UP/DOWN keys to change the priority then press ENTER to exit edit mode. Remember to save your changes.

4.4.5 Selecting the Device Type

This section applies only to the model 340(TS) fire transmitters. The repeater, CP-3000A, smoke detector and CO detector device types cannot be changed and will always be displayed as Repeater, CP-3000A, Smoke Detector and CO Detector respectively. The device type for a model 340(TS) fire transmitter will default to pull station when enrolled and should be changed to reflect the application it is being used for. During an alarm, supervisory or trouble the device type will appear to the left of the description. The device type is simply a label and has no effect on NAC or relay activations. The sample alarm screen below indicates where the device type will appear.

Sample alarm screen showing device type location

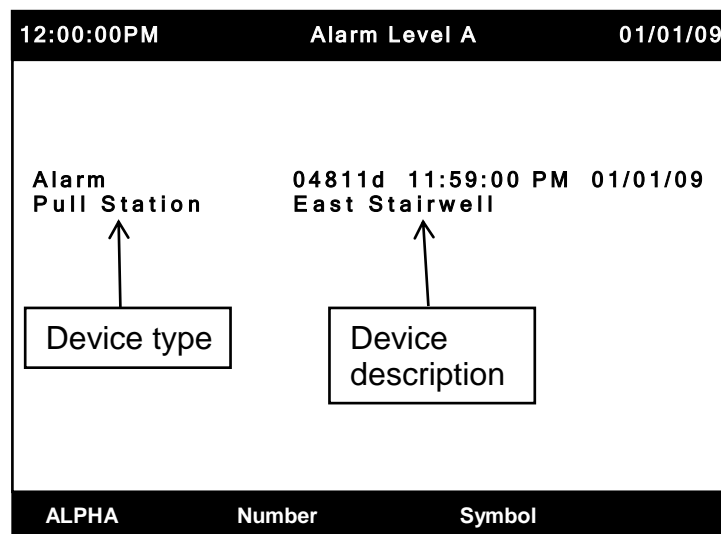

To change the device type, access the edit screen for the desired device. Move the cursor to the device type field and press ENTER. The device type field will now be highlighted. Use the UP/DOWN keys to scroll through the available selections. When the desired device type is shown, press ENTER to select it and exit the edit mode. The available selections are Pull Station, Alarm, Heat Detector, CO Detector, Duct Detector, Flame Detector, Beam Detector, Waterflow, Tamper Switch, PIV, OS&Y, FACP, Remote Reset, Heat/Smoke and Smoke Detector. After the selection is made, be sure to save your changes.

4.4.6 Entering Device, Annunciator and Repeater Description

This section applies to devices, annunciators and repeaters. The CP-3000A description field cannot be edited. Any trouble condition with the CP-3000A will display the device type as CP-3000A and the description field will be blank. The description is limited to 16 characters and can contain letters, numbers and symbols. To enter or change a description, access the device edit screen for the desired device. Move the blinking cursor to the description field and press ENTER. The description field will now be highlighted.

The legends above the soft keys indicate the different groups of characters that can be entered. The current character group will be displayed in all capital letters. The choice defaults to ALPHA meaning letters A-Z. To select a different group, press the appropriate soft key under the desired group and the legend for that group will now be displayed in capital letters. The group can be changed at any time while entering the description.

The ALPHA group contains the letters A-Z in both upper and lower case. Press the UP key and a capitol A will be displayed. Use the UP key to advance to capitol B etc. The lower case letters are chosen by advancing past all of the capitol letters or by pressing the DOWN key while the capitol A is shown.

The NUMBER group contains the numbers 0-9. Press the UP key and the number 0 will be displayed. Use the UP key to advance to 1 etc.

The SYMBOL group contains common symbols such as parenthesis, colon, comma, greater and less than etc. Press the UP key to advance through the symbols until the desired one is displayed.

The method of entering description characters is the same for letters, numbers or symbols. With the description field highlighted, choose the desired group alpha, number or symbol. Use the LEFT/RIGHT keys to move to the desired character in the description then press the UP/DOWN keys to scroll through the letters, numbers or symbols. When the one you want is showing, use the RIGHT key to advance to the next character in the description then use the UP/DOWN keys to select the next one. If you select a capitol letter when the alpha group is selected and then advance to the next character, the letter choice will begin with the lower case letters. You may scroll to the upper case letters if you want to enter the description as all capitols. A space can be inserted between words by simply pressing the RIGHT key twice after the previous word is finished. You can change groups anytime while entering the description. Press the ENTER key when you have completed entering the description. When you press SAVE soft key you will be back on the select device to edit screen. Choose the next device to edit or continue to press BACK until the main CP-3000A screen is displayed.

4.5 NAC and Relay Box Programming

This section contains instructions on programming NAC's on repeaters and the CP-3000A as well as Model RB-10, 20, 30 and 40 relay box relays when connected to a repeater. Never connect a model RB-10, 20, 30, or 40 to a CP-3000A. The programming will not allow you to address them. You will also be able to choose which keypad buttons will reset the activated circuits. **Warning:** **Programming information is transmitted via RF from the CP-3000A to the repeaters. The repeater being programmed must be enrolled, powered on and be able to communicate directly or through another repeater(s) to accept programming information from the CP-3000A. A repeater showing a Test Failure trouble will not be programmed with relay information until it has established communication directly or indirectly with the CP-3000A panel. If a repeater is powered down or loses communication while the programming information is being sent, a Programming Failure trouble will be shown on the CP-3000A for the repeater being programmed. In either scenario, programming will be completed when the repeater once again establishes communication with the CP-3000A.**

4.5.1 Accessing the Repeater Relay Setup screen

To access the repeater relay setup screen, press the program soft key on the main system normal screen. Then scroll down to Repeater Relay Setup and press ENTER. The following screen will be displayed.

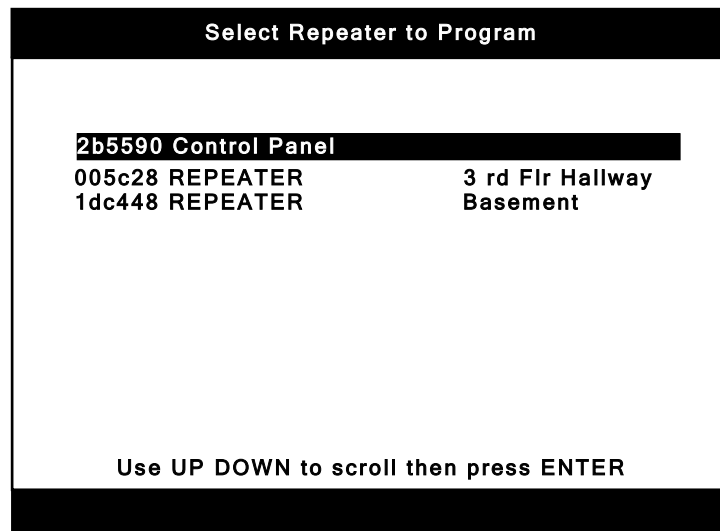

Highlight the repeater to program and press ENTER. The NAC's on the CP-3000A panel can be programmed by selecting Control Panel. If the number of repeaters spans more than one screen page up and page down soft keys will be present. Use the page up and page down soft keys to locate the desired repeater then press ENTER. The following screen will be shown for the selected repeater.

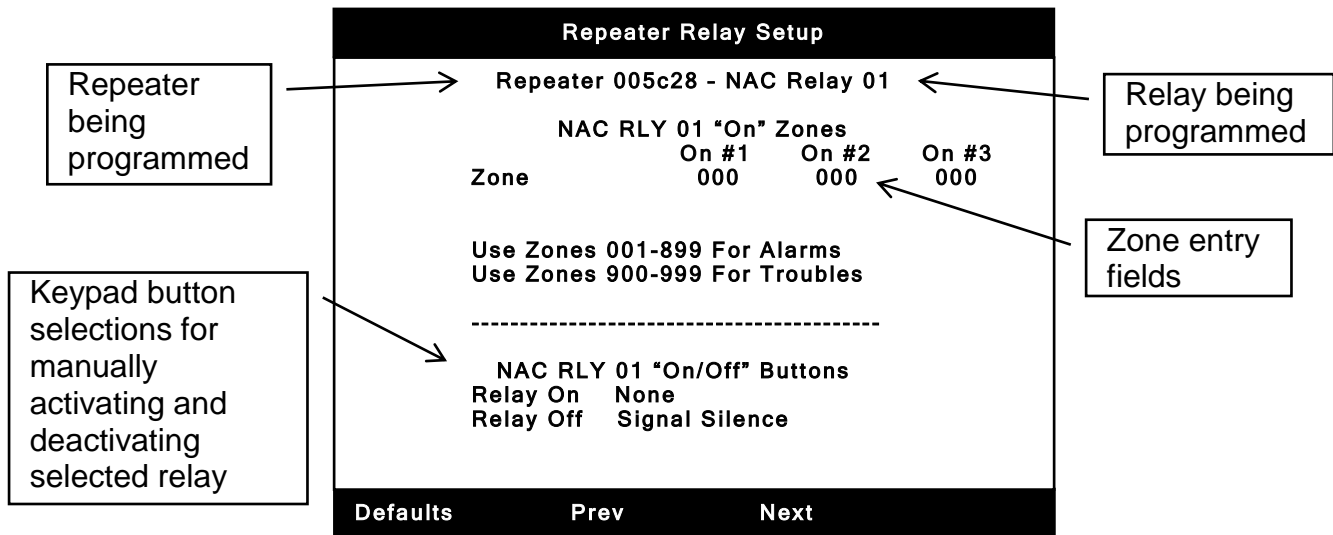

The screen will show the default selections unless the selected relay has been previously modified. The top text line indicates the serial number of the repeater and the specific relay being programmed.

4.5.2 CP-3000A and Repeater NAC and Relay Box Programming

Up to three different zones can be programmed per relay. The three zone fields can be edited as described in 4.4.3 for device zone assignment. Enter the zones programmed into any transmitters which are required to activate the selected relay. When the repeater receives a signal from that transmitter the relay will activate. Keep in mind zones 1-899 respond to alarms and zones 900-999 respond to trouble signals from the transmitter. When you have input the zones press the ENTER key to exit edit mode. **Important: Do not program NAC outputs to activate on any zone which is programmed into a device setup for sprinkler supervisory operation as described in sections 4.4.4 and 4.7 of this manual unless approved by the local AHJ.**

Manual activation is possible in addition to automatic zone activation of a relay. The HORNS ON button can be programmed to manually activate the selected relay. The default is none. This means that the relay will not be activated manually. Selecting Horns On will program the CP-3000A to activate the selected relay manually when the HORNS ON keypad button is pressed. Note: The HORNS ON button will not activate relays when the CP-3000A is in test mode. Refer to the test mode and operation sections of this manual for more information. To program the HORNS ON button to manually activate the selected relay, move the cursor to the Relay On field and press ENTER. Use the UP key to select Horns On then press ENTER to exit edit mode.

Activated relays will always be deactivated if the RESET key is pressed. An additional keypad button can also be selected to deactivate the relay if desired. This will allow restoring select relays to normal without resetting the entire system. To program an additional button for relay deactivation, move the cursor to the Relay Off button field. Press ENTER to enter edit mode then use the UP/DOWN buttons to scroll through the available selections.

The button choices for manually deactivating a relay are Signal Silence, Smoke detector silence, Strobe Reset and Reset only. The default is Signal Silence. Smoke detector silence may be selected in an application where the selected relay must be reset at the same time Model 301 Tandem Smoke alarm sounders are silenced. Strobe Reset may be selected where horns and strobes must be

individually reset. Use of these buttons must comply with NFPA and or local AHJ requirements. The Reset only choice should be selected if the RESET key is to be the only method to restore the output to normal. Specific functions for all of these buttons can be found in the operation section of this manual.

After making all of the desired changes to a relay you can save your information or press the next soft key to advance to the next relay. Pressing the prev soft key will take you one relay back. Pressing prev while displaying NAC RLY 01 will take you to the highest number relay which can be programmed. When programming the CP-3000A NAC's you are only permitted to program NAC RLY 01 and NAC RLY 02. Relay box relays cannot be accessed since you cannot connect any model RB relay box to a CP-3000A. Relay box relay programming is permitted on the AR-3A repeater. The programming is allowed even if no RB series relay box is connected but obviously they can't activate unless they are connected. If you press the NEXT soft key while displaying NAC RLY 02 when programming an AR-3A repeater, the first relay box relay form will be shown. The relay label at the top of the screen will read RB RLY 01. This indicates the first relay of the relay box. Pressing the next soft key will now advance you through the 40 relay box relay programming screens. The screens will advance through all 40 relays even if you have less than 40 connected. The options for the relay box relays are the same as the NAC selections.

When you have finished making the desired changes press the SAVE soft key. This will automatically put you on the Select Repeater to Program screen. If you press BACK without saving you will be prompted to save. If you make many changes on multiple screens before saving there will be a delay after pressing the SAVE soft key before the screen changes to one level back. Be patient and do not press the SAVE soft key multiple times. Once the changes are stored the Select Repeater to Program screen will appear. When you save the changes they are sent via RF signal to the repeater. If you try to edit a relay which was just edited and saved, the CP-3000A will not let you change the programming again until it has finished sending the previous information to the repeater. A message will appear just under the NAC RLY XX line at the top of the screen which reads Last Update Pending, Unable to Edit. If this occurs back out of the relay edit screen and wait a few minutes then try again. You will be allowed to edit the information once the CP-3000A is finished programming the current information into the repeater.

4.6 CP-3000A Auxiliary Output and Dry Contact Relay Programming

This section contains instructions on how to program the Relay 1, Relay 2 and Auxiliary outputs located on the CP-3000A main board. The other outputs on the CP-3000A main board are not programmable. Application information for these outputs can be found in the Systems Outputs section of this manual.

4.6.1 Accessing the CP-3000A Relay Setup Screen

To access the CP-3000A relay setup screen, press the program soft key on the main system normal screen. Scroll down to CP-3000A Setup and press ENTER. The CP-3000A setup menu will now be displayed. Highlight CP-3000A Relay Setup and press ENTER. The following screen will be displayed.

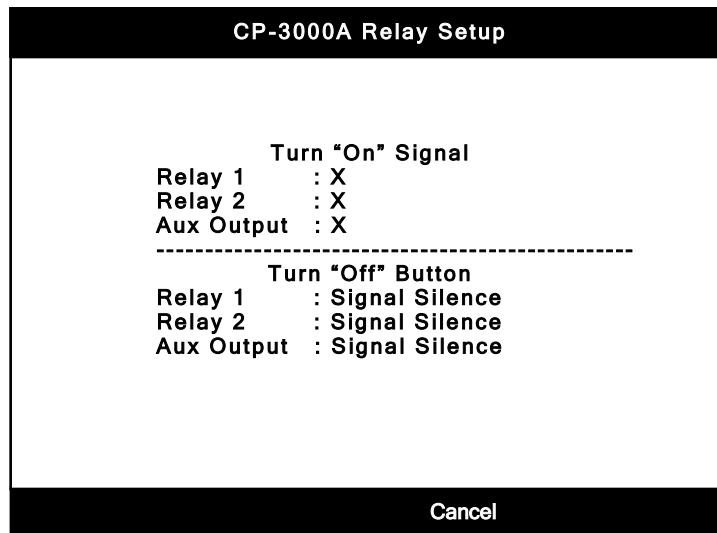

4.6.2 CP-3000A Relay Programming

The screen is divided into two sections, turn on and turn off. These outputs can only be activated with an alarm signal. You can choose any **one** of the alarm priorities A, B, C, or D to activate each output. The alarm priorities are explained in section 4.4.4 of this manual. An X in any of the turn on fields means that output is not programmed to activate. An output will be activated when an alarm signal is received from a device whose priority matches the programming selection for that output. Once an output is activated, it can only be deactivated or turned off manually by pressing a button. Pressing the RESET button will always deactivate the outputs. In addition to the RESET button, the SIGNAL SILENCE button can also be programmed to deactivate an output. The default to turn off these outputs is Signal Silence. The available selections are Signal Silence and Reset. Selecting Reset will keep the output activated until the RESET button is pressed.

To change a turn on field, move the cursor to the desired turn on output field and press ENTER. Use the UP/DOWN buttons to select the alarm priority then press ENTER to exit edit mode. Press the save soft key to save your changes or the cancel soft key to abort the changes.

Important: Any device programmed for sprinkler supervisory as detailed in sections 4.4.4 and 4.7 of this manual will NOT activate the relay 1, relay 2 or Auxiliary outputs even if programmed to do so.

To change a turn off field, move the cursor to the desired turn off button output field and press ENTER. Use the UP/DOWN buttons to change the selection to Reset then press ENTER to exit edit mode. Press the save soft key to save your changes or cancel to abort the changes.

4.7 Supervisory Setup

The CP-3000A can be used for sprinkler supervisory applications. The CP-3000A can be programmed to display sprinkler supervisory alarms from a model 340(TS) Fire Transmitter whose

input is wired to monitor a water flow tamper switch. Only alarm priority C can be used for this application. **Important: For a sprinkler supervisory alarm to report properly the all of the following items MUST be adhered to.**

- 1. Any model 340(TS) Fire Transmitter used for sprinkler supervisory must be programmed for alarm priority C.**
- 2. The sprinkler supervisory feature of the CP-3000A must be turned on as described in this section.**
- 3. Select the appropriate device type for the sprinkler supervisory transmitters as required for the application.**

4.7.1 Accessing the Supervisory Setup Screen

To access the CP-3000A supervisory setup screen, press the program soft key on the main system normal screen. Scroll down to CP-3000A Setup and press ENTER. The CP-3000A setup menu will now be displayed. Highlight Supervisory Setup and press ENTER. The following screen will be displayed.

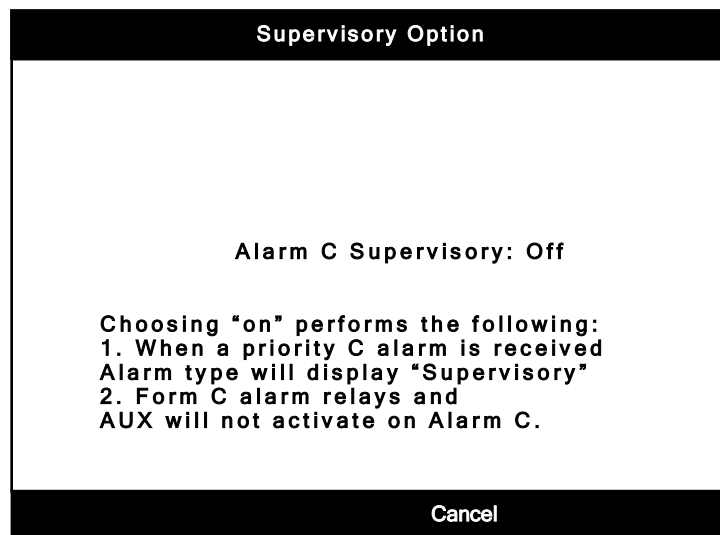

4.7.2 Programming the Sprinkler Supervisory Feature

To activate or deactivate the Sprinkler Supervisory feature, simply press ENTER to edit the field then use UP/DOWN to make the desired selection. Choosing On activates the feature and Off deactivates it. Press ENTER to exit edit mode and save the change.

The device type of the transmitter used for sprinkler supervisory should also be edited to as needed to reflect the particular application such as water flow, tamper switch, PIV, OS&Y etc. Refer to section 4.4.5 to edit the device type. When an alarm occurs from a device programmed for sprinkler supervisory, the word Alarm will be replaced by the word Supervisory. The screen will look similar to the example shown below.



Additional information for sprinkler supervisory can be found in the system interface and operation section of this manual.

4.8 Device Programming and Options

The model 300 is a self contained smoke detector with sounder that can be installed in common areas and living areas. The model 300 sounder will activate the temporal 3 pattern and an alarm will be transmitted when the detector senses smoke. The model 302 is a self contained smoke detector with no sounder intended for installation in common areas. The model 302 will transmit an alarm when it senses smoke. The model 350 is a self contained CO detector with an internal sounder. The model 350 sounder will activate the temporal 4 pattern and an alarm will be transmitted when the detector senses dangerous levels of CO gas. The models 300, 301, 302 and 350 can be assigned zones in the same manner as the model 340(TS) fire transmitters. The model 301 is similar to the 300 and 302 except the CP-3000A can be programmed to activate one or more model 301 detector sounders even if those devices are not detecting smoke. When activated, the sounder will emit the same temporal 3 pattern as if it detected smoke. Application for the model 301 may include apartments where it may be desirable to activate the sounder in the bedroom smoke detector if the living room smoke detector senses smoke. **Notes: Active model 301 tandem sounders will not be synchronized with each other. Models 301 and 350 are intended for installation in living areas. Model 300, 301 and 350 sounders are not intended to replace the main fire alarm sounding device. Do not program models 301 and 350 to activate NACs.**

The tandem feature works based on zones assigned to the smoke detector. Program the detector with up to three zones as described in section 4.4.3. Only use zones 1-899 for tandem smoke detectors. These are the alarm zones. The Model 301 will listen for alarm signals in the installation. If the detector receives an alarm which matches any of its 3 programmed zones, the sounder will activate. **Note: The sounder may take up to 60 seconds to activate.** The alarm signal can be from any type of initiating device compatible with the CP-3000A system. If the originating alarm is from a Model 301 tandem smoke detector, it will also be told to activate its sounder. In this scenario the sounder in the Model 301 which originally detected smoke will continue to emit the temporal pattern even if its chamber is cleared of smoke.

There are also two special zone programming options available for the model 301. The first option is the use of alarm zone 899. This zone is a global alarm zone for the model 301. When an alarm on zone 899 is activated **all** of the model 301 smoke detectors will turn on their sounders. Zone 899 is not required to be entered as any of the three zones in a model 301 for this feature to work. The 301 detectors inherently know 899 as a global activation zone. Enter 899 in any of the three zone positions in a device and when that device sends an alarm it will activate the 301 sounders.

The second option is the function of the third zone position on a model 301. The first two zones work the same as any other device however the third zone on a model 301 is unique. Two or more model 301 tandems with the same zone number in the third zone entry position **will not** activate each other's sounders when they are in alarm. This only applies to a model 301. An alarm from any other device such as a model 340(TS) or 300 with any zone position matching the model 301 third zone **will** activate that detectors sounder.

The Model 301 tandem smoke detectors can also be manually activated and deactivated using buttons on the keypad. Manual activation and deactivation of tandem sounders is a global function and will affect ALL Model 301 tandem smoke detectors in the installation. The Horns On button can be programmed to manually activate the tandem detector sounders. The Smoke detector silence or Reset button can be programmed to deactivate the tandem detector sounders. These buttons must be programmed in the CP-3000A to provide these functions. **Note: Silencing a tandem smoke detector sounder may take up to 60 seconds.**

4.8.1 Accessing the Tandem Control Menu

Manual activation and deactivation of the tandem smoke detectors can be programmed under the Tandem SD Controls program menu item. To access this menu press the program soft key on the main system normal screen. Scroll down to Tandem SD Controls and press ENTER. The tandem smoke detector setup menu will now be displayed as shown below.

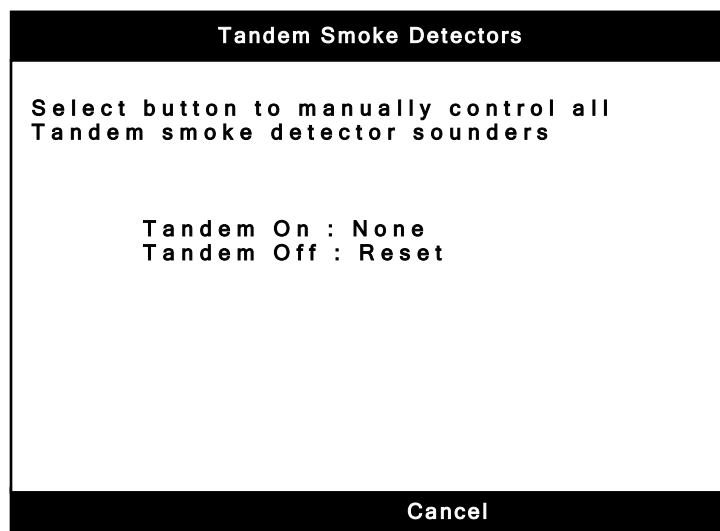

4.8.2 Programming Tandem Manual Activation and Deactivation

The default for Tandem On is "None". This means the tandem detector sounders in the installation will only be activated by zones. The Horns On button can be selected to activate all tandem

sounders. To program the Horns On button to activate ALL tandem detectors, move the cursor to the Tandem On field and press ENTER. Use the UP/DOWN keys to select Horns On then press ENTER to exit edit mode. Remember to save your changes.

The default for Tandem Off is "Reset". This means the tandem detector sounders in the installation will be reset when the RESET button is pressed. This also resets the CP-3000A control panel back to normal. It may be desirable to reset ALL of the tandem detector sounders but leave the CP-3000A in the alarm state. The Smoke detector silence button can be programmed for this function. It will silence the tandem sounders but leave the CP-3000A showing alarms etc. To program the Smoke detector silence button to silence the tandem sounders, move the cursor to the Tandem Off field and press ENTER. Use the UP/DOWN keys to select Smoke Sndr Silence then press ENTER to exit edit mode. Remember to save your changes.

4.8.3 Remote Reset Feature

The CP-3000A can be reset with an rf signal from a model 340(TS) transmitter. This allows the CP-3000A to be restored to normal when a third party facp is reset. Refer to the 340 manual (p/n IM-340) for wiring and testing information.

To use the remote reset function enroll a model 340 transmitter and change the device type to remote reset and save. Shorting the contacts of a 340 transmitter set to a remote reset device type will reset the CP-3000A. Resetting the Cp-3000A with the remote reset will show in the all event log as a remote reset. **Note: Zones cannot be entered and the alarm level cannot be changed on a 340 programmed as a remote reset. The CP-3000A and 3rd party facp must be installed in the same room and within the same field of vision.**

4.9 Unknown and Ignored Units

The unknown and ignored units are lists of devices that checking in but are not enrolled into the CP-3000A. Devices will appear on the unknown list in conjunction with an unknown device trouble as described in the system operation trouble section of this manual. If a device that is not enrolled that has the same base code as the CP-3000A tries to check in it will be displayed as an unknown device trouble and be placed on the unknown device list. The CP-3000A will not display or respond to any troubles or alarms from a device on the unknown list. An unknown device may appear for any of the following reasons:

1. The device was deleted from the CP-3000A without removing the battery first. As soon as the device tries to check in it will show as an unknown trouble and be placed on the unknown list. Remove the battery from the device.
2. A device from another CP-3000A installation with the identical base code tries to check in with your CP-3000A. **Warning: Be sure you know whether the device belongs to your installation or not. If it doesn't then look for a neighboring system which may be on the same base code and change the base code of your CP-3000A to a number different than the other installation. CHANGING THE BASE CODE ON THE CP-3000A WILL REQUIRE ALL ENROLLED DEVICES TO BE DELETED AND ENROLLED AGAIN.**
3. A device is powered up which is not enrolled and has the same base code as the CP-3000A. The CP-3000A should be put into enrollment mode before attempting to enroll any device.

The Ignored units are devices that have been moved from the unknown unit list to the ignored unit list. Moving a device to the ignored list requires a manual button press and will never occur automatically. Devices moved to the ignored list will no longer show an unknown device trouble. This feature can be handy if you need to delete a device from the CP-3000A and cannot physically locate

it to remove the battery. This should not be common practice and only used as a last resort.

Warning: An alarm, supervisory or trouble received from a device on the unknown list will be displayed as an unknown unit trouble.

4.9.1 Displaying the Unknown Unit Screen

The unknown units list can be displayed by pressing the PROGRAM soft key then select the Unknown Units menu item and press ENTER. The following is an example of one device being displayed on the unknown units screen.

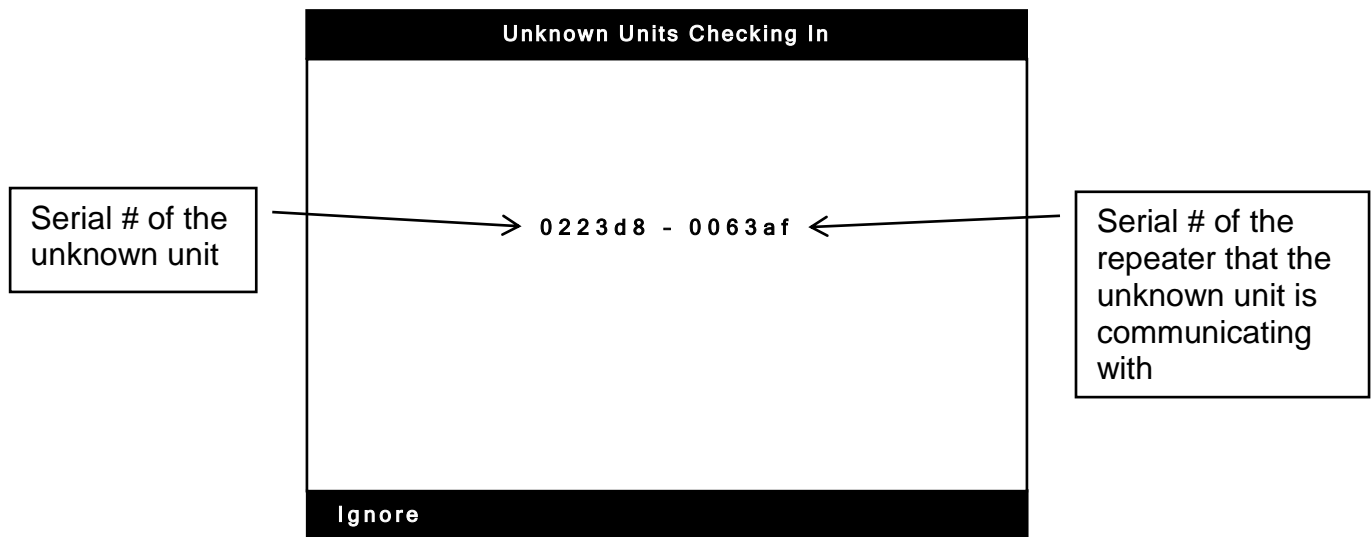

The unknown device serial number will be displayed on the left and the serial number of the repeater it is reporting to on the right. The two are separated by a dash. A repeater serial number of 000000 indicates the unknown device is no longer reporting to any enrolled repeater.

4.9.2 Removing a Device from the Unknown List

To remove a device from the unknown list the installer can choose to ignore it. If Ignore is chosen the device will be moved to the ignored list and will no longer show an unknown trouble. **Warning: Do not move an unknown device to the ignored list if you cannot identify it as being part of your installation. If you are receiving unknown units that you cannot identify which may be from another installation, the correct solution is to change the base code of your CP-3000A.**

To move the device to the ignored list, highlight the desired device and press the ignore soft key.

Note: Any device appearing on the Unknown Units list will continue to show an unknown unit trouble until it has been either ignored or enrolled. The device can only be enrolled after it is ignored and then removed from the ignored list.

4.9.3 Displaying the Ignored Unit Screen

The ignored units list can be displayed by pressing the PROGRAM soft key then select the Ignored Units menu item and press ENTER. The following is an example of one device being displayed on the unknown units screen.

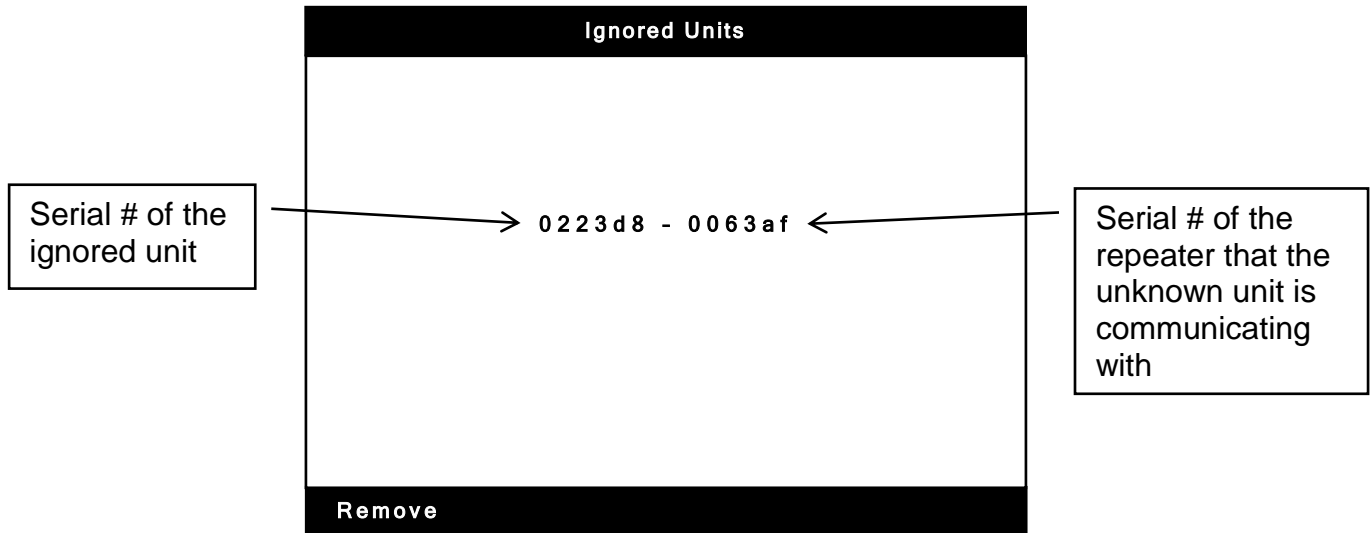

The ignored device serial number will be displayed on the left and the serial number of the repeater it is reporting to on the right. The two are separated by a dash. A repeater serial number of 000000 indicates the unknown device is no longer reporting to any enrolled repeater.

4.9.4 Removing a Device from the Ignored List

The devices on this list were placed here by choosing ignore on the unknown list. This should have only been done if you know where the device is and there is no need for it to continue to send an unknown device trouble. Devices can remain on the ignored list indefinitely. **Warning: The CP-3000A will not respond to alarms, supervisory or troubles received from devices on the ignored list.** To remove a device from the Ignored list the installer can choose to remove it.

If remove is chosen, the device will no longer be shown on the ignored list. If the device tries to check into the CP-3000A it will cause an unknown device trouble and be placed back onto the unknown list.

You may also enroll the device by following the instruction for enrolling a device in section 3.4.1 in this manual. **You must first remove the device from the ignored list before you can enroll it.** After the device is enrolled the CP-3000A will again respond to troubles and alarms from the device.

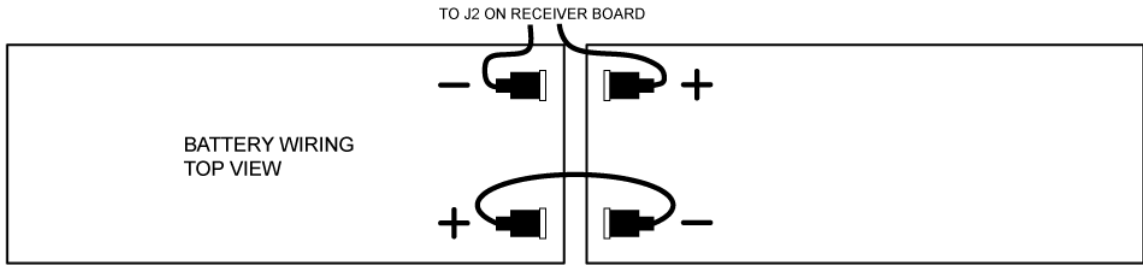
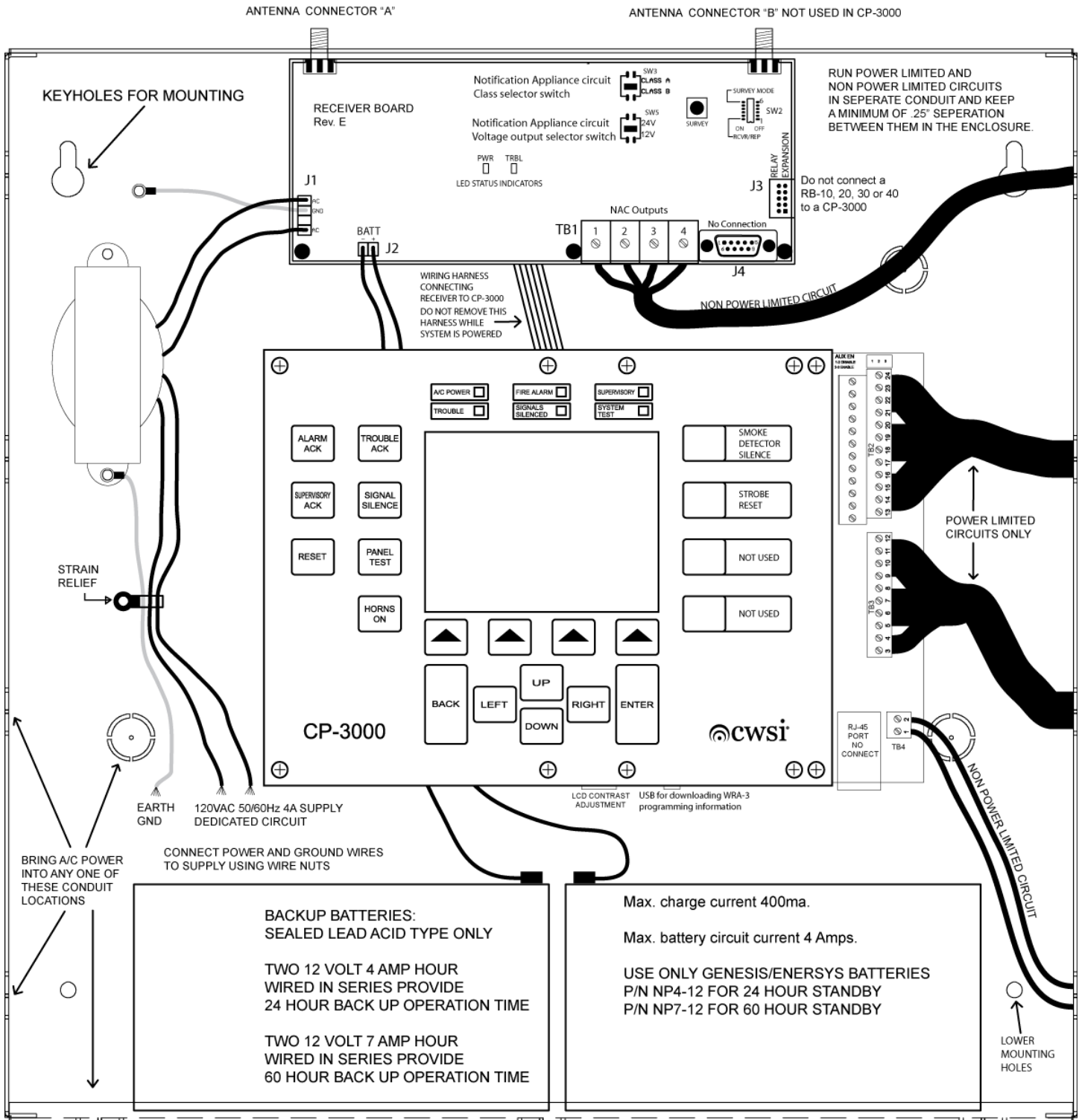

Figure 4
43

Section 5 - System Outputs

The CP-3000A has 10 dry contact, 1 auxiliary and 1 class A or 2 class B NAC output circuits available. Some are programmable and some are common. Each output and function is explained below. Refer to figure 5 for the diagram of these outputs. All diagrams are shown with system power connected and control panel in normal mode.

5.1 Dry Contact Outputs

5.1.1 Alarm A, B, C, D Contacts (TB2 Terminals 17-24)

These 4 normally open common type outputs will operate when any alarm signal of the corresponding A, B, C or D type is being processed. For example if alarm A has been designated for smoke detectors and a smoke detector alarm is received the alarm A relay will activate. When alarm C is configured for supervisory then the alarm C relay will serve as a supervisory output. The outputs will reset when the CP-3000A Reset key is pressed. These are common type relays for connection to power limited circuits only. Wiring from these terminals must be in conduit and contained within one room. Power limited and non power limited circuits must be separated by at least .25" within the enclosure and run in different conduit. Refer to figure 4 for suggested wire routing. These outputs are also used when connecting the control panel to a communicator. They have double terminals so that an end of line resistor can be connected in different terminals than those used for wiring connections allowing connected equipment to properly monitor any wiring fault. Refer to the communicator section of this manual for approved communicator and proper connection. The contacts are rated at 24Volts D.C. 1 Amp resistive. Acceptable wire size for connection is 16-22awg.

5.1.2 Trouble Contacts (TB2 Terminals 13-16 N.O. and TB3 Terminals 3-6 N.C.)

There are 2 normally open and 2 normally closed trouble dry contact common type outputs available on the CP-3000A. They will operate during processing of any of the trouble conditions listed in the system operation section of this manual or when the system is placed in test mode. These also serve as the fail safe relays that monitor for system processor failure and total power down of the control panel. The trouble outputs will reset when the CP-3000A Reset key is pressed. These are common type relays for connection to power limited circuits only. Wiring from these terminals must be in conduit and contained within one room. Power limited and non power limited circuits must be separated by at least .25" within the enclosure and run in different conduit. Refer to figure 4 for suggested wire routing. The normally open outputs have double terminals so that an end of line resistor can be connected in different terminals than those used for wiring connections allowing connected equipment to properly monitor any wiring fault. The terminal output designations shown in figure 5 are with system power applied in normal standby mode. One of the normally open trouble outputs is used when connecting the control panel to a communicator. Refer to the communicator section approved communicator and proper connection. When a power loss trouble occurs at the system, repeater or annunciator, activation of the trouble relays will be delayed by 90 minutes. This delay is factory set and cannot be changed. The contacts are rated at 24Volts D.C. 1 Amp resistive. Acceptable wire size for connection is 16-22awg.

5.1.3 Relay 1+2 form C Outputs (TB3 Terminals 7-12)

These are 2 form C programmable unsupervised outputs. One of the 4 alarm types A or B or C or D can be programmed to activate these outputs. Each relay can be programmed independently. The reset method for the alarm contacts is also programmable. These outputs are for connection to power limited circuits only. Wiring from these terminals must be in conduit and contained within one room. Power limited and non power limited circuits must be separated by at least .25" within the enclosure and run in different conduit. The contacts are rated at 24Volts D.C. 1 Amp resistive. Acceptable wire size for connection is 16-22awg. Note: When Alarm C is designated for sprinkler supervisory these relays outputs will not activate during a sprinkler supervisory alarm even if programmed to do so. Refer to the programming section for programming options and instructions.

5.2 NAC Auxiliary and Other Outputs

5.2.1 Auxiliary Output Local Energy Municipal Box Service (TB4 Terminals 1+2)

This is a programmable output for connection to a city municipal box using series connection only. Shunt connection is not supported. This is a non power limited connection. Power limited and non power limited circuits must be separated by at least .25" within the enclosure and run in different conduit. Refer to figure 4 for suggested wire routing. This output is supervised for open circuit and ground fault. **Note: The wiring integrity of the aux output is only supervised if it is programmed to activate.** One of the alarm types A or B or C or D can be programmed to activate this output. A jumper labeled JP1 located on the CP-3000A motherboard can be used to disable the auxiliary output. Placing the jumper on pins 1+2 will disable the output. This is useful when tripping of the municipal box is not desired while performing system testing in normal operation mode. Disabling this output will cause a system aux trouble to be displayed. Removing the jumper completely or placing it on pins 2+3 will enable the output to function if programmed. Note: The auxiliary output must first be programmed to activate before the auxiliary output will function. There are multiple activation and reset options available when this output is used. Refer to the programming section for further instructions. Note: Alarm C will not activate the auxiliary output when it is designated as sprinkler supervisory even if programmed to do so.

Output Ratings:

- Alarm current 350 ma.
- Alarm voltage 3.65 Vdc
- Coil resistance 14.5 ohms
- Max. coil resistance 14.6 ohms
- Max. wire resistance 3 ohms
- Ground Fault detection resistance 1000 ohms or less

Note: The following rules must be followed when wiring to the Auxiliary output:

1. The wiring from the Aux. output to the city box must be less than 1000 feet.
2. The wiring must be underground.
3. The wiring must be run in a separate trench from power lines.

ALL RELAY CONTACTS SHOWN WITH SYSTEM POWER APPLIED AND IN NORMAL STANDBY MODE

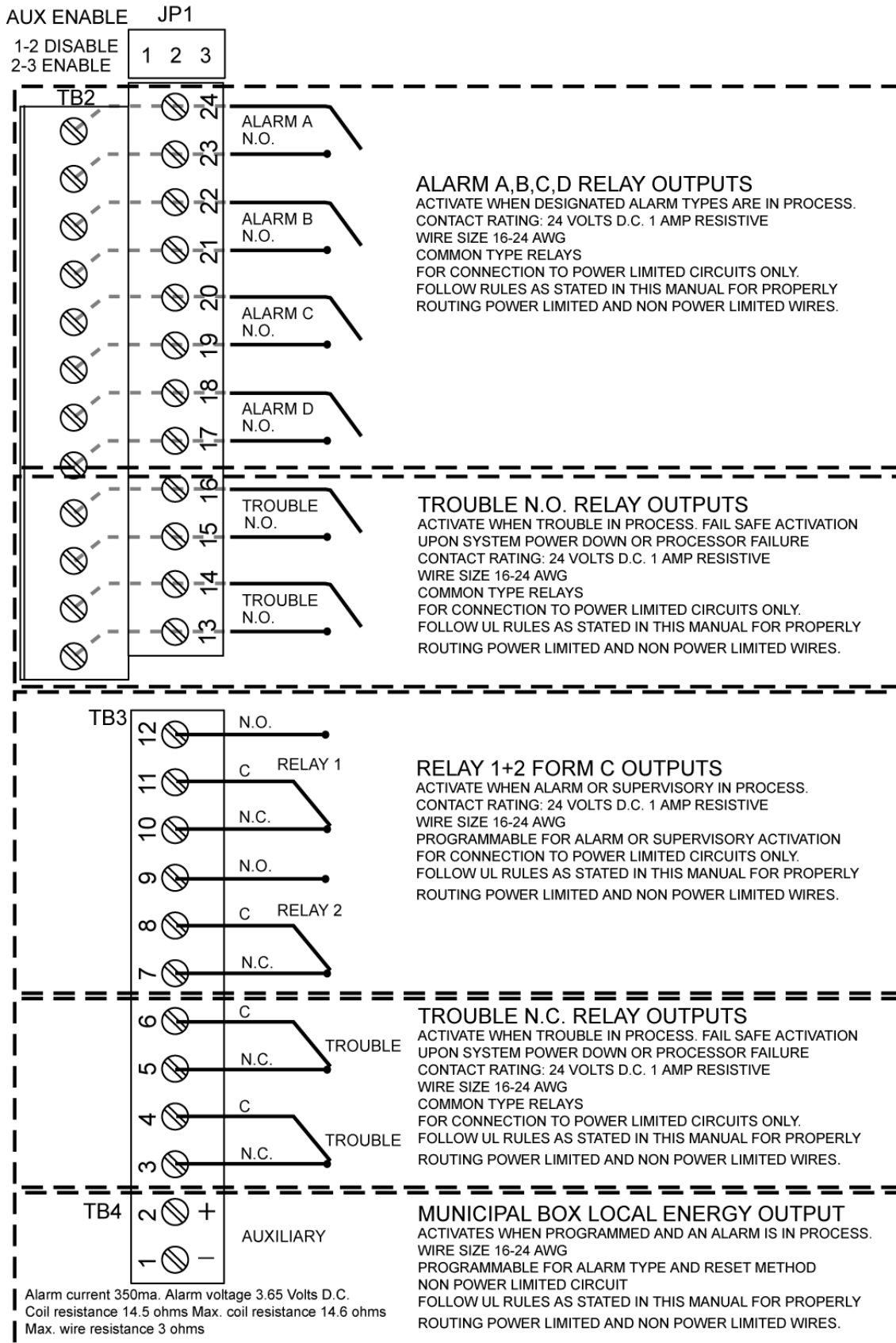

Figure 5

5.2.2 Notification Appliance Circuits (TB1 Terminals 1-4 on receiver card)

The CP-3000A control panel provides a notification appliance circuit which is field selectable for either 1 Class A Style Z or 2 Class B Style Y supervised non power limited outputs. The NAC output is both a special application and regulated output. The power limitations for each application are listed below. Power limited and non power limited circuits must be separated by at least .25" within the enclosure and run in separate conduit. **Note: All wiring from the TB1 connector must be run in conduit and contained within one room. Use minimum 18 awg wire.** Refer to figure 4 for suggested wire routing. The outputs are supervised for wiring integrity and ground fault. Output voltage is also selectable between 12 and 24 Volts D.C. as shown in figure 6. The Class and voltage are determined by the settings of SW3 and SW4 on the receiver card. The NAC circuit connector is labeled TB1 and located on the lower right edge of the receiver card. When operating on back up batteries the CP-3000A will maintain the NAC circuit output voltage within UL limits even if the battery voltage drops to the low battery threshold of 20.4 Vdc. The NAC circuits are also site programmable for activation and deactivation. Refer to the programming section for complete activation and deactivation programming options. The circuits utilize current sensing technology and if the rated current draw is exceeded a NAC overload trouble signal will be displayed and the NAC circuit output will deactivate. It will attempt to reactivate only if another device programmed to activate it sends an alarm or the NAC circuit is reset by the control panel and then reactivated by another alarm. In class B operation, an end of line resistor P/N TR-3 must be placed at the last appliance connected to the circuit or an eol violation trouble will be displayed on the CP-3000A. **Note: A TR-3 eol resistor is only required if the NAC outputs are programmed to activate.** A ground fault trouble will also be displayed if a ground fault of 1000 ohms or less is present on a NAC circuit. Figure 6 shows proper wiring of NAC circuit. Table 1 shows compatible notification appliances. Horn and strobe synchronization is achieved by using one of the compatible synchronization modules. The NAC outputs can also be synchronized together using the listed sync modules.

Special Application NAC Output ratings:

- Class B – 2 output circuits

 - Non power limited over current protected

 - 12 Volts D.C. @ 1.75 Amps or 24 Volts D.C. @ 1 Amp each

- Class A – 1 output circuit

 - Non power limited over current protected

 - 12 Volts D.C. @ 1.75 Amps or 24 Volts D.C. @ 1 Amp

Regulated NAC Output ratings:

- Class B – 2 output circuits

 - Non power limited over current protected

 - 12 Volts D.C. @ 175 milliamps or 24 Volts D.C. @ 100 Milliamps each

- Class A – 1 output circuit

 - Non power limited over current protected

 - 12 Volts D.C. @ 175 milliamps or 24 Volts D.C. @ 100 Milliamps

5.2.3 Notification Appliance Compatibility

The following UL Listed notification appliances are compatible with the CP-3000A Control Panel

Table 1

MANUFACTURER	MODEL NUMBER	TYPE	SW4 SETTING	MAX PER NAC
WHEELLOCK	HSR/HSW	HORN/STROBE	24 Volts	1
WHEELLOCK	DSM-12/24-R	SYNC MODULE	24 Volts	1
SYSTEM SENSOR	P2R/P2W	HORN/STROBE	12 or 24 Volts**	4
SYSTEM SENSOR	MDL3R or MDL3W	SYNC MODULE	24 Volts	1
SYSTEM SENSOR	R-20E	RELAY	24 Volts	4*

CONTACT MANUFACTURER FOR COMPLETE PART NUMBERS AND OPTIONS.

REFER TO MANUFACTURER DOCUMENTATION FOR PROPER WIRING OF SYNC MODULES

* UP TO 4 RELAYS CAN BE CONNECTED WITHOUT ANY NOTIFICATION APPLIANCES CONNECTED OR SUBSTITUTE 1 RELAY FOR 1 NOTIFICATION APPLIANCE IF USED TOGETHER. WHEN USING R-20E RELAYS THEY SHOULD BE CONNECTED DIRECTLY TO THE NAC OUTPUTS BEFORE THE SYNC MODULE.

** ONLY SET CANDELA RATING TO 15 OR 15/75 WHEN SW4 IS SET TO 12 VOLTS.

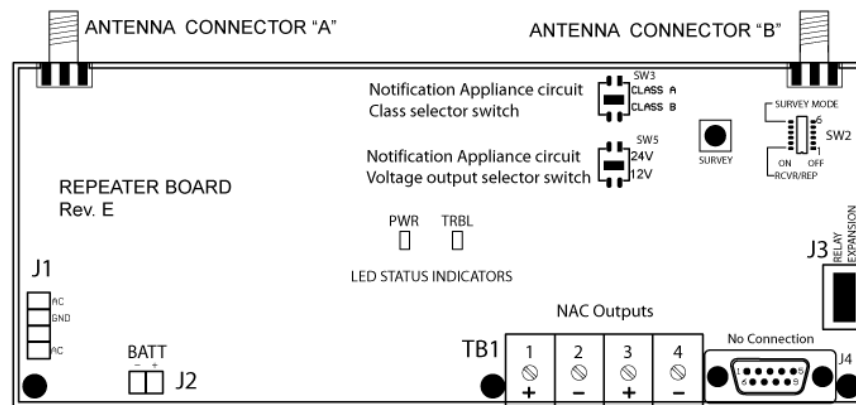

POLARITIES SHOWN IN ALARM STATE

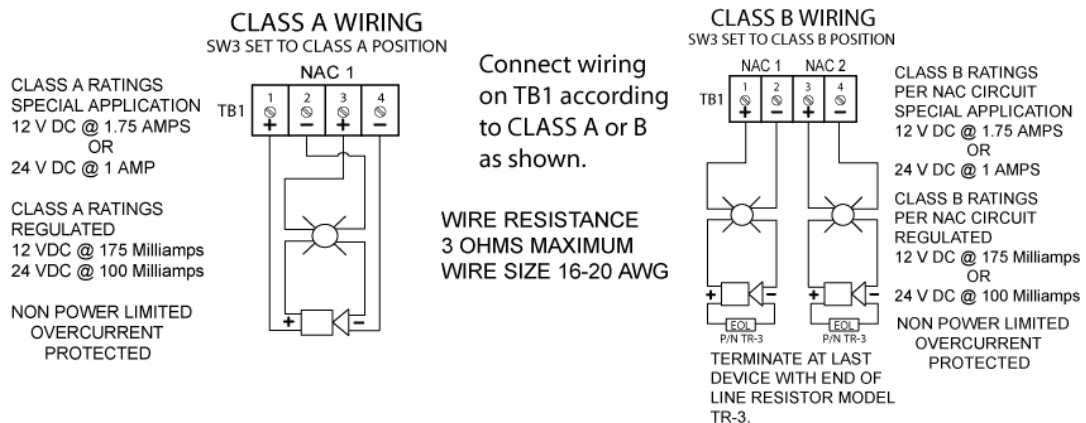

Figure 6

5.2.4 RS-232 Serial Connector

The serial connector is located on the receiver card in the lower right hand corner as shown in figure 4. Its designation is J4. This connector is for factory use only. Connecting any equipment to this connector may damage the CP-3000A.

5.2.5 Ethernet Connection

The Ethernet connector is located on the bottom right corner of the main CP-3000A board as shown in figure 4. This connection is for factory use only. No user information can be obtained from this connector. The MAC address of the system can be found on the Ethernet jack.

5.2.6 USB Connector

This connector is located on the lower left hand side of the main CP-3000A board as shown in figure 4. This connector is for downloading WRA-3 programming information with the WRA-3 programming tool. Refer to the WRA-3 manual for more information.

5.2.7 Relay Expansion Connector

The relay expansion connector is not for use in the CP-3000A control panel.

Section 6 - System Interface and Operation

6.1 Visual Displays, User Interface and Internal Sounder

An LCD and LEDS are used to provide visual indications for current status of the CP-3000A. The LCD display will show the current status and display menus for programming the CP-3000A. LEDS are provided for indication of A/C Power, Fire Alarm, Supervisory, Trouble, Signal Silence and Test. The membrane switch panel is used to control and program all aspects of the CP-3000A. Refer to figure 7. The LCD, LEDS and button functions are described below.

6.1.1 LCD

The 5" diagonal 340 x 240 backlit LCD allows for pinpoint status display of any abnormal conditions occurring as well as programming information and other useful necessary information as mentioned throughout this manual. The backlight will illuminate as follows:

A/C power applied:

1. Continuously when an alarm, supervisory or trouble is present on the CP-3000A.
2. For 3 minutes after a button on the keypad is pressed.

Running on battery backup:

1. Continuously when an alarm or supervisory is present on the CP-3000A
2. For 30 seconds when a trouble is received.
3. For 30 seconds after a button on the keypad is pressed.

A contrast adjustment is provided to accommodate installation locations which make the factory setting difficult to view the displayed information. It is located under the keypad on the main CP-3000A board adjacent to the Ethernet connector. It is labeled Cont. Adj. Using a small screwdriver rotate the adjustment until the desired contrast is achieved. Only adjust the contrast while the LCD

backlight is on. Do not adjust the contrast too light as to make the display unreadable or too dark as to make the display totally black.

6.1.2 LEADS

There are 6 led lights located on the keypad for visual indications as listed below.

A/C power

This LED is on when continuous when proper A/C is present and flashes during brown out or total loss of A/C power. Restoring A/C power from an A/C loss or brown out condition will automatically change the status of the power led from blinking to on continuous.

Fire Alarm

This LED flashes when any unacknowledged Alarm condition is present on the CP-3000A. It will turn on steady when all alarms have been acknowledged. Any Alarm from a device other than ones currently present and acknowledged will cause the Alarm LED to flash again. Resetting the CP-3000A will turn this LED off.

Supervisory

This LED flashes when any unacknowledged Supervisory alarm condition is present on the CP-3000A. It will turn on steady when all higher priority Alarms have been acknowledged and the Supervisory Ack or Signal Silence is pressed. Any Supervisory alarm from a device other than ones already currently present and acknowledged will cause the Supervisory LED to flash again. Supervisory alarms cannot be acknowledged until higher priority alarms are acknowledged. Resetting the CP-3000A will turn this LED off.

Trouble

This LED flashes when any unacknowledged Trouble condition is present on the CP-3000A. It will turn steady when all Alarm and Supervisory conditions have been acknowledged and the Trouble Ack button is pressed. Any Trouble from a device other than ones already currently present and acknowledged will cause the Trouble LED to flash again. Troubles cannot be acknowledged until all Alarm and Supervisory conditions are acknowledged. Resetting the CP-3000A will turn this LED off.

Signals Silenced

This LED turns on when any programmed silence button is pressed with an Alarm condition present. If NAC circuits are reactivated or the CP-3000A is reset, this led will go out. The silence buttons are Signal Silence, Smoke detector silence and Strobe Reset.

System Test

This LED turns on when the CP-3000A is placed in test mode. Resetting the system to normal will turn this LED off.

6.1.3 Buttons

There is a total of 21 membrane buttons, which are accessible only after unlocking the cabinet door. These buttons provide means for total system control and programming. All button presses involving operation of the CP-3000A and every time the pass code is entered will be stored in the button press log for later retrieval if needed. The Back, Enter, Up, Down, Left, Right and menu select arrow soft

key buttons are used for functions other than operation will not be logged into the button press log when pressed.

Buttons and functions are:

Alarm Ack

This button is used for acknowledging an Alarm or to view multiple priority Alarms. Pressing this button will acknowledge all unacknowledged alarms, silence the internal piezo sounder and change the Fire LED from flashing to steady. If a different device transmits an Alarm while acknowledged Alarm(s) are present, the piezo will resound and the Fire LED will flash. Pressing the Alarm Ack button will acknowledge the new Alarm. If multiple priority Alarms are present and unacknowledged a single press of the Alarm Ack button will acknowledge all of them. Pressing the Alarm Ack button again after acknowledging multiple priority Alarms will rotate the display to show the next lowest priority A, B, C or D alarm. Continue pressing the Alarm Ack button to scroll through and view all different priority Alarms. If the Alarm Ack button is pressed while the CP-3000A is displaying the lowest level Alarm then the CP-3000A will go back to displaying the highest priority Alarm. Pressing this button will also send a record to the button press log.

Supervisory Ack

This button is used for acknowledging a Supervisory alarm. Pressing this button will acknowledge all unacknowledged supervisory alarms, silence the internal piezo sounder and change the Supervisory LED from flashing to steady. If a different device transmits a Supervisory alarm while acknowledged Supervisory alarm(s) are present, the piezo will resound and the Supervisory LED will flash. Pressing the Supervisory Ack will acknowledge the new Supervisory alarm. If an acknowledged Supervisory alarm remains on the system for more than 4 hours and the system is not reset, the piezo will resound. Pressing the Supervisory Ack button will silence the piezo for another 4 hour period. Pressing this button will also send a record to the button press log.

Trouble Ack

This button is used for acknowledging a Trouble condition. Pressing this button will acknowledge all unacknowledged troubles, silence the internal piezo sounder and change the Trouble LED from flashing to steady. If acknowledged Trouble(s) are present and a different device transmits a Trouble or a presently acknowledged device sends a different type of Trouble, the piezo will resound and the Trouble LED will flash. Pressing the Trouble Ack will acknowledge the new Trouble condition. If an acknowledged Trouble remains on the system for more than 4 hours and the system is not reset, the piezo will resound. Pressing the Trouble Ack button will silence the piezo for another 4 hour period. Pressing this button will also send a record to the button press log.

Signal Silence

The operation of this button is similar to the Alarm Ack button except it will not scroll through multiple priority acknowledged Alarms. Use the Alarm Ack button for this function. The Signal Silenced button can be programmed to reset any active NAC circuits, Form C relays, Auxiliary output, Model RB 10-40 relays and Model 301 Tandem Smoke Detector sounders. The Signals Silenced LED will turn on and the message "Signals Silenced" will appear on the LCD when this button is pressed while an alarm is present. Pressing this button will also send a record to the button press log. **The Signal Silence button must be programmed to perform any of these functions. Follow local fire codes and AHJ instruction when using this button.**

Smoke Detector Silence

The operation of this button is similar to the Alarm Ack button except it will not scroll through multiple priority acknowledged Alarms. Use the Alarm Ack button for this function. The intended use of this button is to silence Model 301 tandem smoke detector sounders but the Smoke Detector Silence button can also be programmed to reset any active NAC circuits and Model RB 10-40 relays. The Signals Silenced LED will turn on and the message “Smoke Detector Sounders Silenced “will appear on the LCD when this button is pressed while an alarm is present. Pressing this button will also send a record to the button press log. **The Smoke Detector Silence button must be programmed to perform any of these functions. Follow local fire codes and AHJ instruction when using this button.**

Strobe Reset

The operation of this button is similar to the Alarm Ack button except it will not scroll through multiple priority acknowledged Alarms. Use the Alarm Ack button for this function. The intended use of this button is to reset NAC’s that are controlling strobes. This button can also be programmed to reset any active NAC circuits and Model RB 10-40 relays. The Signals Silenced LED will turn on and the message Strobes Reset “will appear on the LCD when this button is pressed while an alarm is present. Pressing this button will also send a record to the button press log. **The Strobe Reset button must be programmed to perform any of these functions. Follow local fire codes and AHJ instruction when using this button.**

Reset

Pressing this button will reset the CP-3000A system to normal standby operation. All active LED’s, NAC circuits, Dry contact relays, Auxiliary output, RB 10-40 relays, LCD display and piezo will be restored to normal standby condition. If the system is in test mode, pressing the reset button will take the CP-3000A out of test mode. If any Alarm, Supervisory or Trouble that exists after reset will cause the system to once again annunciate that condition.

Panel Test

Pressing this button while the CP-3000A is in normal standby will activate the Test LED. Refer to the system testing section for additional information. Pressing reset will return the system to normal standby.

Horns On

When pressed, this button will activate any NAC circuits and/or Model 301 sounders, turn the piezo on steady and the words “Alarm Circuits Activated will appear on the LCD screen. Pressing this button will also send a record to the button press log. **The Horns On button must be programmed to perform these functions. Refer to programming section for options.**

Enter

This button is used for system programming. Refer to programming section.

Back

This button is used for system programming. Refer to programming section.

Up, Down, Left, Right

These buttons are used for system programming and LCD display navigation.

4 Soft arrow keys

These buttons provide access to the menus used for configuration, programming, memory logs and system info. They also provide other functions where necessary. The user may be prompted to enter

the pass code when accessing programming functions with any of these buttons. The current button function will appear on the LCD screen just above the buttons.

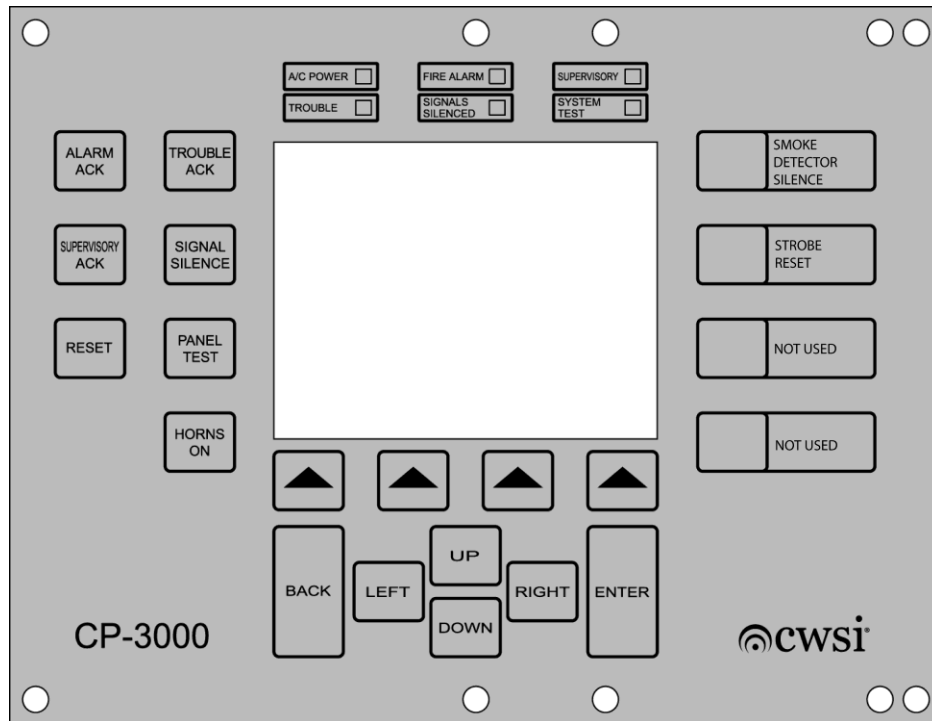

Figure 7

6.1.4 Sounder

The CP-3000A internal sounder is a piezo horn which will annunciate a different sound pattern for Alarm, Supervisory and Trouble as follows:

Alarm – On continuous

Supervisory – 1 second on, one second off

Trouble – 1 second on every 10 seconds

These sounds will be annunciated when any unacknowledged Alarm, Supervisory or Trouble condition is in process. Acknowledging the highest priority signal will silence the sounder if no other unacknowledged lower priority conditions exist. If an unacknowledged lower priority condition exists, the sounder will annunciate the associated pattern for that condition. The sounder will also reactivate if a different device other than the ones already acknowledged transmits an Alarm, Supervisory or Trouble signal or if a presently acknowledged device sends a different type of Trouble. If the CP-3000A is not reset to normal within 4 hours of acknowledging a Trouble, the sounder will reactivate with the trouble pattern to indicate the acknowledged devices are still present on the CP-3000A. Pressing the TROUBLE ACK button will again silence the sounder for another 4 hours.

6.2 System Operation

6.2.1 General

This section will give details on operation of the CP-3000A control panel including responding to Alarm, Supervisory and Trouble signals, Test mode, Memory functions and the associated LCD screens displayed during all of these operations. The programming of features, buttons, relays and transmitter/repeater enrollment is contained in the programming section of this manual.

6.2.2 Normal Standby

Normal standby mode exists when no off normal conditions are occurring in the installation. The LCD screen shown below will be present during normal mode. When in normal mode the CP-3000A is monitoring system voltages, keypad inputs, etc. as well as monitoring for any off normal alarms, supervisory or trouble signals. Transmitter test signals are also logged during normal operation.

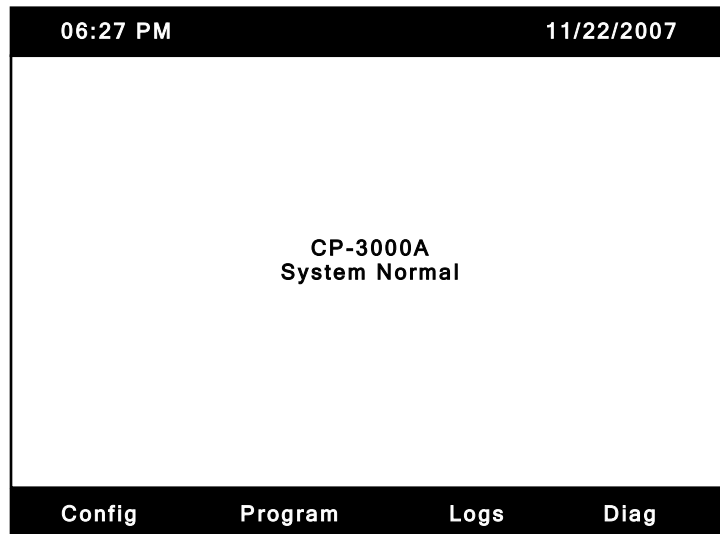

6.2.3 Alarm

Alarms can be generated by any of the compatible initiating devices listed in this manual. Upon reception of an alarm signal from an initiating device the following will occur:

1. Any lower priority conditions currently displayed on the LCD will be replaced by the higher level alarm. The lower priority condition can be redisplayed only when the higher one is acknowledged.
2. The alarms will be displayed in the order of oldest to newest.
3. The sounder will emit a steady tone.
4. The Fire Alarm LED will flash once a second.
5. The corresponding normally open alarm relay (A, B, C or D) will activate.
6. The form C relays will activate if programmed to do so.
7. The CP-3000A NAC circuit outputs will activate if programmed to do so.
8. Any repeater NAC circuits programmed to turn on will activate.
9. The Auxiliary output will activate if programmed to do so.
10. The event is stored in the alarm and all event log.

The membrane buttons will function as described in section 6.1.3. If unacknowledged lower priority signals are present, they can be displayed as each higher priority signal is acknowledged. The LCD display shown below is an example of the LCD display when multiple alarms spanning more than one screen are in process.

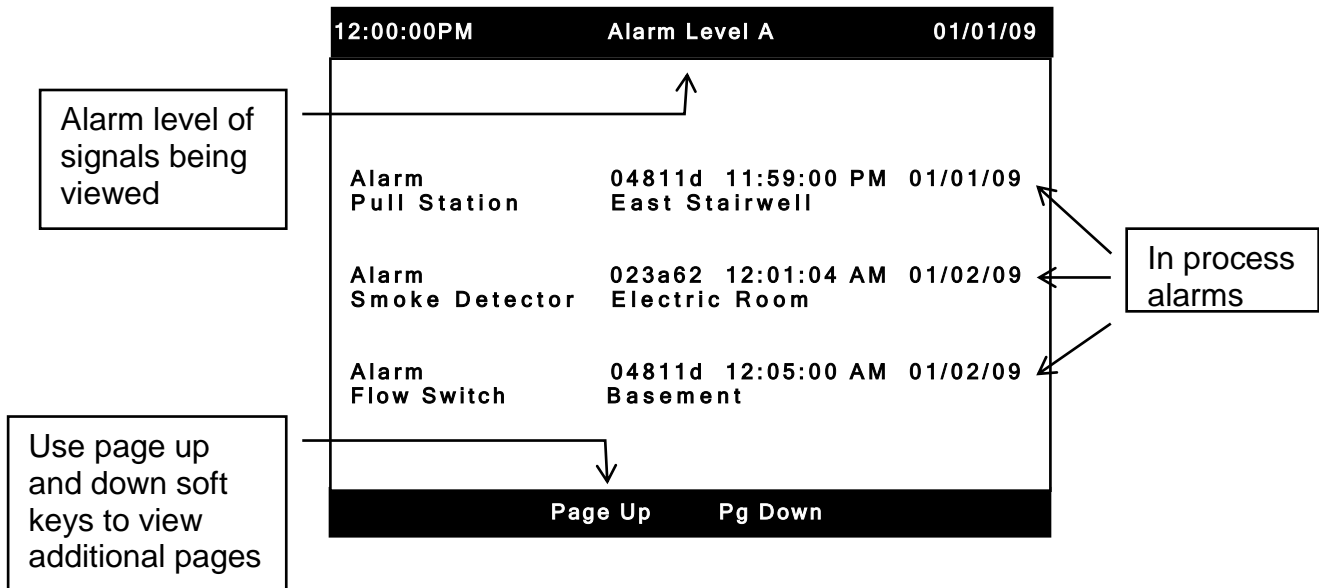

The alarm level currently being viewed will be shown at the top of the screen along with the time and date. The page up and page down soft keys will appear when number of signals spans more than one LCD page. Use these keys to view alarms on other pages.

6.2.4 Sprinkler Supervisory

Alarm C can be programmed for sprinkler supervisory operation during programming of the system. Upon reception of a supervisory signal the following will occur.

1. Any lower priority conditions currently displayed on the LCD will be replaced by the sprinkler supervisory display.
2. The sounder will pulse once a second.
3. The sprinkler Supervisory LED will flash once a second.
4. Alarm Relay 3 will activate.
5. Relay 1, Relay 2 and auxiliary outputs will not activate.
6. The event is stored in the alarm and all event log.

The membrane buttons will function as described in section 6.1.3. If unacknowledged lower priority signals are present, they can be displayed as each higher priority signal is acknowledged. The LCD display shown below is an example of the LCD display when multiple supervisory alarms spanning more than one page are in process. **NAC circuits must not be programmed to activate upon receipt of a sprinkler supervisory signal.**

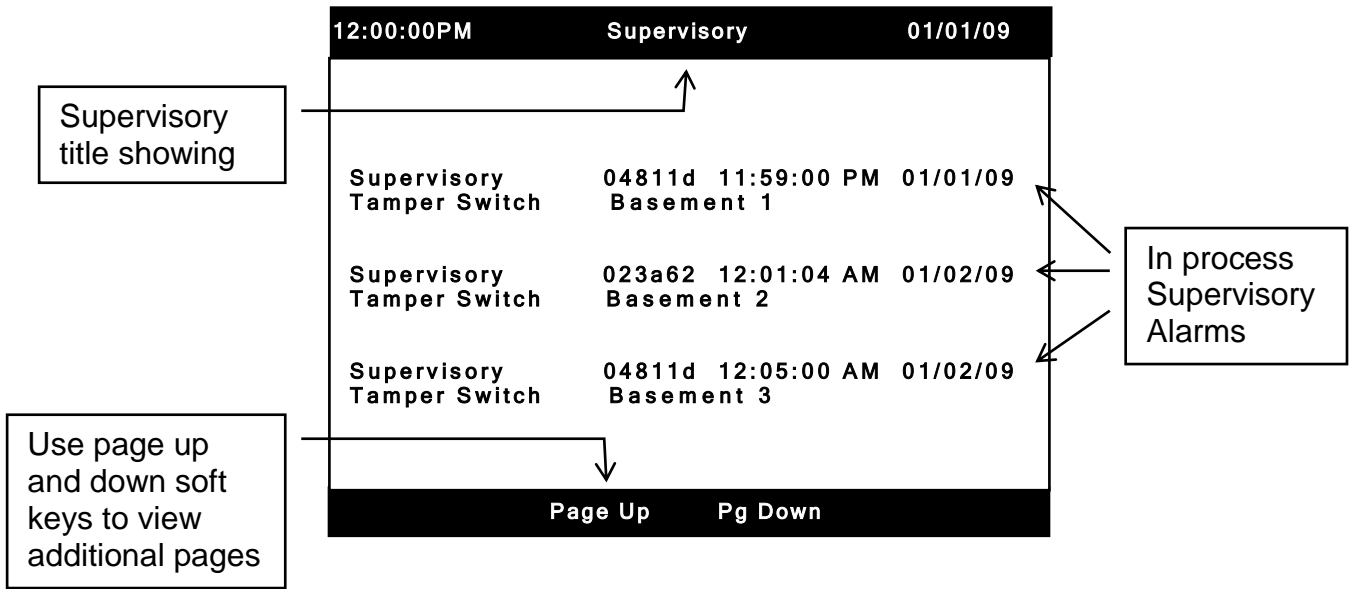

The supervisory title will be shown at the top of the screen along with the time and date. The page up and page down soft keys will appear when number of signals spans more than one LCD page. Use these keys to view supervisory alarms on other pages.

6.2.5 Trouble Signals

A trouble signal indicates a problem with a device(s) or the control panel. Trouble signals should not be programmed to activate any NAC relays or alarm circuits. Upon reception of a trouble signal the following will occur:

1. Multiple trouble signals of different types will be displayed in the order time of occurrence from oldest to newest.
2. The sounder will pulse once every 10 seconds.
3. The trouble LED will flash once a second.
4. The form C trouble contacts will activate.
5. The event is stored in the trouble and all event log.

The membrane buttons will function as described in section 6.1.3. The LCD display shown below will be present when multiple troubles spanning more than one page are in process.

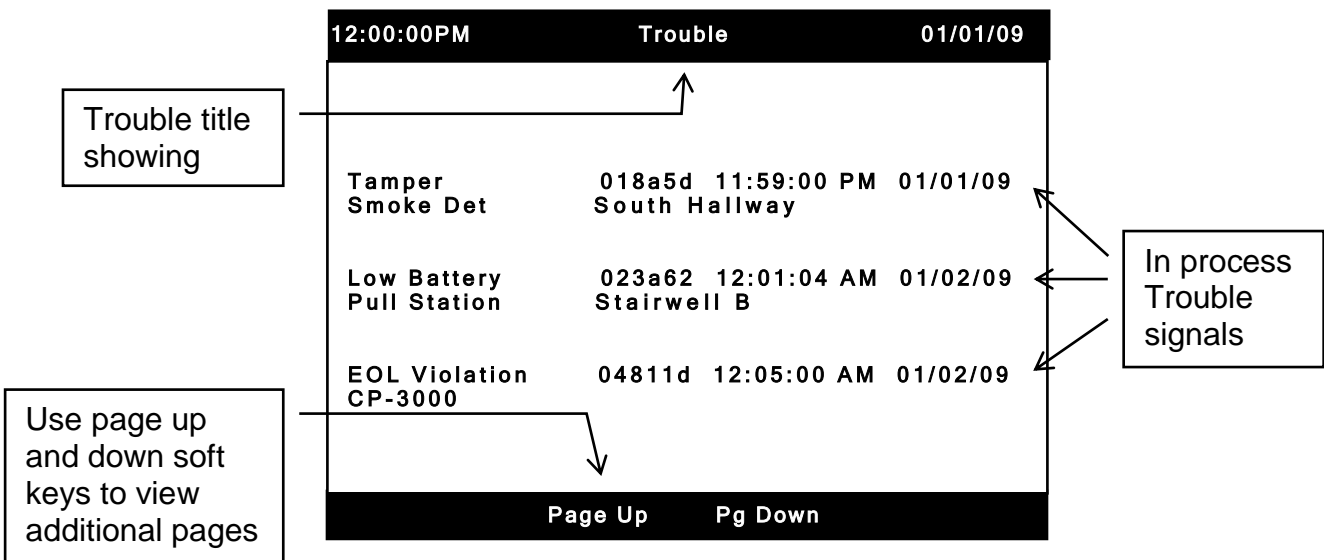

The trouble title will be shown at the top of the screen along with the time and date. The page up and page down soft keys will appear when number of signals spans more than one LCD page. Use these keys to view trouble signals on other pages.

Below is a list of trouble signals with causes and possible solutions.

1. **Power Loss** – Can occur in a WRA-3 annunciator, AR-3A repeater or CP-3000A control panel. Caused by low or no voltage present at A/C input to product. CP-3000A trouble relay activation will be delayed by 90 minutes. Check the A/C power source for the affected unit. This trouble is self restoring.
2. **Ground Fault** – Can occur in an AR-3A repeater or CP-3000A control panel. Caused by a NAC or Auxiliary output wiring short to earth ground of 1000 ohms or less. Check the wiring for shorts to earth ground.
3. **Hardware Failure** – Can occur in a CP-3000A panel or models 300 and 301 smoke detectors. Caused by loss of communications between the receiver and main CP-3000A board or a smoke detector internal component problem. Power cycle the CP-3000A or smoke detector. If the problem persists, the unit needs factory service.
4. **Aux Circuit** – Can occur in a CP-3000A control panel. Caused by an open in the wiring connected to the Aux circuit. Check the wiring for opens.
5. **Tamper** – Can occur in any battery operated device. Caused by removal of device or exposing device battery. Make sure the device is mounted correctly.
6. **Tamper/Maint** – Can occur in a model 350 CO detector. Caused by removal of the device, open sensor or sensor end of life.
7. **Test Failure** – Can occur in an AR-3A repeater or any device. Caused by the CP-3000A not receiving a device polling transmission within 200 seconds. Check to see if the affected unit has power. Perform a signal survey from the device and verify it is good.
8. **EOL Violation** – Can occur in an AR-3A repeater or CP-3000A panel. Caused by an open circuit or short circuit in the NAC wiring preventing the unit from reading the end of line resistor. Check the wiring for shorts and opens.
9. **Program Fault** – Can occur in an AR-3A repeater or CP-3000A control panel. Caused when an AR-3A repeater or CP-3000A control panel does not accept programming commands. Make sure the affected unit has power and perform a signal survey test or power cycle the unit. If the problem persists the unit will require factory service.
10. **Charger Fault** – Can occur in an AR-3A repeater or CP-3000A panel. Caused by problem in battery charging circuit. Unit will require factory service.
11. **Low Battery** – Can occur in any CWSI battery operated or A/C powered device, repeater or CP-3000A panel. Caused by battery voltage being too low or faulty batteries. Let the batteries charge or replace the batteries.
12. **Maintenance Req** – Can occur in models 300 and 301 smoke detectors. Caused by dirt in the smoke chamber or hardware failure in the smoke detector head. Clean the smoke detector. If the problem persists, replace the unit.
13. **Power Up Reset** – Will occur when any enrolled device is powered up. This is a normal occurrence and does not indicate a trouble. A trouble is indicated if the device sends a Power Up Reset signal anytime after initial power up. If this occurs, the unit should be returned to the factory for repair.
14. **Unknown Unit** – Can occur when a device, annunciator or repeater that is not enrolled is checking into the CP-3000A control panel. Refer to section 4.9 in this manual for more information.

- 15. **Memory Error** – Will occur if the CP-3000A is unable to access any of its internal memory. The display will show “Unable to access memory device”. This trouble will require factory service.
- 16. **Checksum Bad** – Will occur when the programming information between the CP-3000A and any enrolled annunciator does not match. Program the annunciator(s) as described in the WRA-3 manual.

6.2.6 System Test

The system test is designed to allow testing of all installed devices without activating any NAC’s or relay outputs. This test is commonly used for annual testing of the devices in an installation. The CP-3000A can only be placed into test mode while the System Normal screen is showing. To enter the test mode press the PANEL TEST button. All of the leds will flash three times then the CP-3000A will display the test mode screen as shown below. The trouble relays will be activated and the sounder will emit the trouble pattern while the CP-3000A is in test mode.

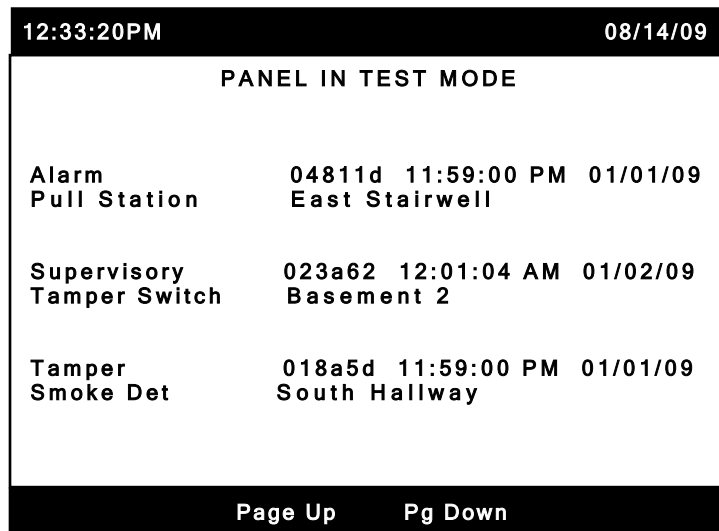

The devices will show on the LCD as they are activated. They will be displayed the same as if the system was in normal operation. Alarm and Supervisory signals received while in test mode are stored in the test log instead of the alarm and all event logs. Trouble signals are not stored in any log while in test. The test log can be viewed after the testing is finished if necessary. The test log has a capacity of 1000 signals. The Page Up and Page Down soft keys can be used to scroll through the signals if desired. You can exit the test mode at any time by pressing the RESET key. Multiple occurrences of the same type signal from any one device will only be displayed once while in test. If you want to test the same signal from a transmitter more than once you will have to exit and reenter test mode. **Caution: If an actual alarm is received from a device that is not being tested, it will not activate any NAC or relay circuits. For this reason it is important to recognize such an occurrence as this could be a real fire condition somewhere in the installation which requires immediate attention. If this is the case you should exit the test mode by pressing the RESET key and allow the alarm to be processed normally.**

6.2.7 Event Logs

The CP-3000A has 4 alarm logs Alarm, Trouble, All Event and Test. These logs are provided for viewing of events in chronological order as they occurred including time and date of each event. Each log has a 1000 event limit. If the limit is exceeded the oldest event will be replaced by event 1001 and so on. All of the logs will display events in the order of newest to oldest.

Each logs function is explained below.

1. Alarm Log – Records all Alarm and Supervisory events while the CP-3000A is not in test mode. This log cannot be erased. Limit is 1000 events.
2. Trouble Log – Records all Trouble events while the CP-3000A is not in test mode. This log cannot be erased. Limit is 1000 events.
3. All Event Log – Records all the events of the Alarm and Trouble log and also records button presses in the order they occurred while the CP-3000A is not in test mode. The buttons that will be logged are RESET, HORNS ON, PANEL TEST, ALARM ACK, SUPERVISORY ACK, TROUBLE ACK, SIGNAL SILENCE, SMOKE DETECTOR SILENCE and STROBE RESET. This log cannot be erased. Limit is 2000 events.
4. Test Log – Records all Alarms and Supervisory signals received while the CP-3000A is in test mode. Trouble signals will not be logged. This log can be erased. Limit is 1000 events.

The log menu can be accessed from the system normal screen by pressing the Log soft key. Enter the password if prompted. After pressing the log key the log menu will be displayed. Use the UP/DOWN keys to select the desired log to view. The last selection is Clear Test Log. Choose this option if you want to erase the contents of the test log. You will be prompted to confirm the choice. The test log contents are permanently erased when this option is chosen. Example views of the different logs are shown below.

Sample Alarm Log

12:33:20PM		08/14/09	
Alarm Log			
Alarm	04811d	12:59:00 AM	01/03/09
Pull Station	East Stairwell		
Supervisory	033a92	12:32:04 AM	01/02/09
Tamper Switch	Basement 2		
Alarm	023a62	04:01:04 PM	01/01/09
Smoke Detector	Electric Room		
Alarm	04cf53	12:05:00 AM	12/28/08
Flow Switch	Basement		
Last Pg		Pg Down	

Sample Trouble Log

12:33:20PM	08/14/09
Low Battery Pull Station	Trouble Log 04811d 12:59:00 PM 01/03/09 East Stairwell
EOL Violation Repeater	033a92 12:01:04 AM 01/02/09 Basement 2
Aux Circuit CP-3000	023a62 05:23:04 PM 01/01/09
AC Pwr Loss Repeater	04cf53 12:05:00 AM 12/02/08 2nd Floor Hallway
Last Pg	Pg Down

Sample All Event Log

12:33:20PM	08/14/09
Reset	All Event Log 12:10:00 AM 01/02/09
Supervisory Tamper Switch	033a92 12:02:04 AM 01/02/09 Basement 2
Horns On	12:02:00 AM 01/02/09
Alarm Smoke Detector	023a62 12:01:04 AM 01/02/09 Electric Room
Low Battery Repeater	04cf53 11:59:00 PM 01/01/09 2nd Floor Hallway
Correct Password	10:28:03 AM 12/28/08
Last Pg	Pg Down

Sample Test Log

12:33:20PM		08/14/09	
Test Log			
Alarm Pull Station	04811d	12:59:00 AM	01/03/09 East Stairwell
Supervisory Tamper Switch	033a92	12:32:04 AM	01/03/09 Basement 2
AC Pwr Loss Repeater	04cf53	12:05:00 AM	01/03/09 2 nd Floor Hallway
Alarm Flow Switch	03d913	12:01:00 AM	01/03/09 Basement
Last Pg		Pg Down	

Use the Pg Up, Pg Down, Last Pg and Top Pg to navigate through multiple screens. These navigation buttons will appear when applicable above the associated soft key. Press the BACK key to exit from viewing any log screen. If an alarm is received while viewing any log screen, the CP-3000A will exit log viewing and display the alarm.

6.2.8 System and Programming Information

The CP-3000A has two information menus that provide the installer and AHJ with current system and programming information. The system info page will give software revision numbers, MAC address, current base code etc. pertaining to the CP-3000A. The programming info provides a summary of the current programming of the CP-3000A including NAC, enrolled devices, etc.

6.2.9 Accessing the System Info Screen

To access the system info screen, press the Sys Info soft key while the CP-3000A system normal screen is showing. Enter the password if prompted to do so. The System Diagnostics menu will now be shown. Highlight System Info and press enter. The screen below will be shown.

System Info Screen

12:33:20PM		08/14/09	
System info			
MAC Address		:01:13:EB:99:78:98	
IP Address		:0.0.0.0	
Serial Number		:0429b3	
System Version		:2.1	
Base Code		:046	
No. of Repeaters		:20	
No. of Devices		:375	
No. of Annun.		:2	
Build Date		:Jul 8 2009	

The information on the System Info screen is mainly used for technical assistance. If you call CWSI for technical assistance you may be asked for this information. The information is described below.

1. MAC Address – This is the MAC address of the Ethernet port. The Ethernet port is for factory use only.
2. IP Address – The IP address would appear here if the Ethernet jack was connected to a host. This will be 0.0.0.0 when not connected.
3. Serial Number – This is the serial number of the CP-3000A control panel.
4. System Version – This is the software version in the CP-3000A control panel.
5. Base Code – This is the current base code of the CP-3000A as described in this manual. The info screen provides an easy way to view it.
6. No. of Repeaters – The number of currently enrolled repeaters is shown here.
7. No. of Devices – The number of currently enrolled devices is shown here.
8. No. of Annun. – The number of currently enrolled annunciators is shown here.
9. Build Date – Refers to the build date of the software in the CP-3000A control panel. This may be used if you call technical service.

Press the BACK key to exit the System Info screen. If an alarm is received while viewing the System Info screen, the CP-3000A will exit viewing and display the alarm.

6.2.10 Accessing the Programming info Screen

To access the programming info screen, press the Sys Info soft key while the CP-3000A system normal screen is showing. Enter the password is prompted to do so. The System Diagnostics menu will now be shown. Highlight programming Info and press ENTER. The Programming Info screen will now be displayed.

The information on the Programming info screen provides a summary of the all of the programming options selected for the CP-3000A as well as all of the enrolled repeaters and devices. The summary can be quite long depending on how many devices, annunciators and repeaters are enrolled. The information shown is not segregated per page. For instance some of the control panel info may be split into two or three pages with no divider. Use the PAGE UP, PAGE DOWN, LAST PAGE and TOP PAGE soft keys to view all of the information. The programming is presented in a slightly different format than it is in the actual programming screens so it may take a few minutes to recognize how this information applies to the programming selections.

The information is divided into three sections:

1. CP-3000A Settings – This section includes current base code and all other relay programming options as described in this manual.
2. Enrolled units – This section includes all of the enrolled devices and their associated zone programming, priority, serial number and description.
3. Enrolled Annunciators – This section includes all of the enrolled annunciators and their associated serial number and description.
4. Enrolled Repeaters – This section includes all of the enrolled repeaters and their associated serial number and NAC programming.

Examples of the Programming Info sections are shown below.

CP-3000A Settings section

12:33:20PM	08/14/09
Programming Info	
CP-3000A Settings	
Network Basecode:	046
Supervisory:	On
Relay 1	
On: B	Off: Reset Only
Relay 2	
On: A	Off: Reset Only
Auxiliary	
On: A	Off: Reset Only
 Control Panel: 0429b3 - NAC RLY: 01	
Last Pg	Pg Down

Enrolled Units Section

12:33:20PM	08/14/09	
Programming Info		
Enrolled Units		
Unit: 04811d [Pull Station]		
Zone 1: 100	Zone 2: 000	Zone 3: 000
Priority: A	Desc: East Stairwell	
 Unit: 03d913 [Flow Switch]		
Zone 1: 025	Zone 2: 000	Zone 3: 000
Priority: B	Desc: Basement	
 Unit: 033a92 [Tamper Switch]		
Zone 1: 000	Zone 2: 000	Zone 3: 000
Priority: C	Desc: Basement 2	
Last Pg	Pg Down	

Enrolled Annunciators

12:33:20PM	08/14/09
Programming Info	
Enrolled Annunciators	
Annunciator: 680017	
Desc: North Entrance	
 Annunciator: 680039	
Desc: West Entrance	
Last Pg	Pg Down

Enrolled Repeaters Section

12:33:20PM	08/14/09
Programming Info	
Enrolled Repeaters	
Repeater: 04cf53 Desc: 2 nd Floor Hallway	
Relay Rules	
Repeater: 04cf53 - NAC RLY: 01	
Zone 1: 100	Zone 2: 000 Zone 3: 000
On: None	Off: Signal Silence
Repeater: 04cf53 - NAC RLY: 01	
Zone 1: 025	Zone 2: 000 Zone 3: 000
On: Horns On	Off: Strobe Reset
Last Pg	Pg Down

Press the BACK key to exit the Programming Info screen. If an alarm is received while viewing any programming info screen, the CP-3000A will exit viewing and display the alarm.

Section 7 - Digital Alarm Communicator

7.1 Installation and Wiring

The CP-3000A can be connected to a Silent Knight Model 5104B UL864 9th edition approved communicator in an installations requiring off premises communication. When it is wired and programmed as detailed in this section the 5104B will allow off premises central station notification of all alarm types (A, B, C, D) and any trouble signals received by the CP-3000A control panel. The communicator has the capability of either 24 or 60 hour battery backup time.

7.1.1 Installation

Follow the instructions in the communicator manual for mounting the unit. **Note: The communicator must be installed such that the display annunciation at each unit can be simultaneously observed. All wiring must be in conduit and contained within the same room.** The 5104B should be configured for standalone operation. The 5104B will use its own power supply and back up batteries as a power source. **Do not wire the 5104B to use any power source directly from the CP-3000A.**

7.1.2 Wiring

The wiring connections between the CP-3000A and 5104B are straight forward and will require 10 wires to be connected. Use the wire type and size recommended in the 5104B manual. All of the wiring is power limited. Always run power limited and non power limited wiring in separate conduit. Maintain at least ¼" between power limited and non power limited wiring within each enclosure. The CP-3000A N.O. Alarm A, Alarm B, Alarm C and Alarm D outputs will be connected to the 5104B Zones 2, 3, 4 and 5 respectively. One of the CP-3000A N.C trouble outputs will be connected to the 5104B Zone 6 input. All of the connections are supervised by the communicator. Use the EOL resistors supplied with the 5104B to terminate the connections at the CP-3000A. The EOL resistors for monitoring the alarm wiring should be connected to the upper TB2 terminal block across each N.O. alarm output relay A, B, C, and D on the CP-3000A. The alarm wiring connections on the CP-3000A should be connected to the lower terminals of TB2 across each N.O. alarm output relay A, B, C and D. The EOL resistor for the trouble output is wired in series with the Zone 6 input on the 5104B dialer. Zone 1 on the 5104B is not used and must be terminated in Class A configuration at the communicator terminals. Refer to figure 8 for proper wiring connections.

7.2 Programming and Operation

7.2.1 Programming

The 5104B must be programmed for standalone operation as described in the communicator manual. There is one possible programming change in the 5104B from the default settings. The change is for programming Zone 4 on the 5104B to report as a sprinkler supervisory. Zone 4 must be programmed to report as sprinkler supervisory if Alarm C on the CP-3000A is programmed for supervisory operation. This setting will make the CP-3000A and 5104B compliant to the UL 864 standard. **Note: The programming instructions in this manual are intended to make the interface between the CP-3000A and 5104B UL 864 compliant. You must program the 5104B with the telephone number, account info etc. in order to report to the central station properly. Refer to the 5104B manual for further information.**

CP-3000A to 5104B Communicator Wiring

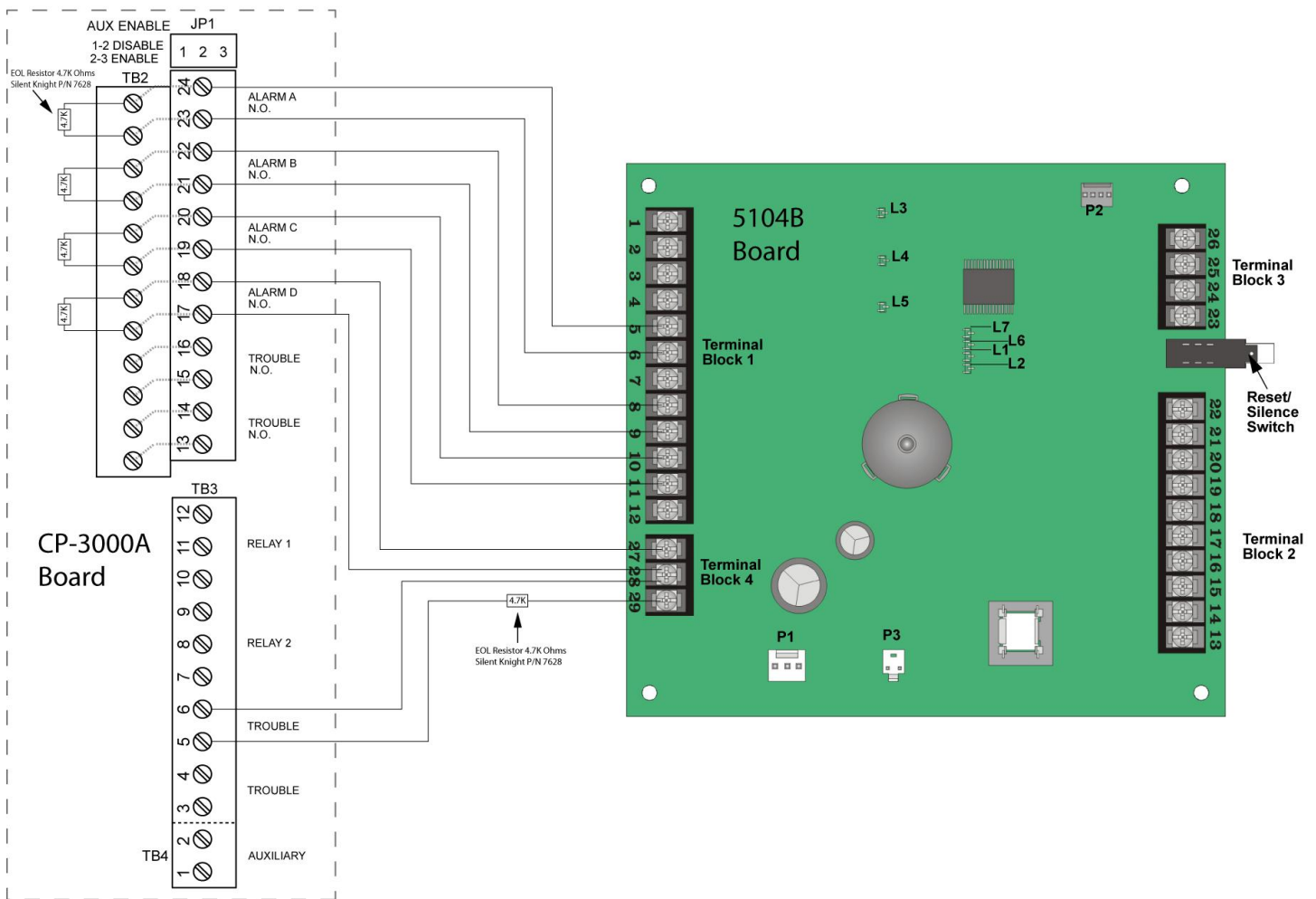

Figure 8

Once the wiring and programming of the CP-3000A and 5104B are complete, any alarms, supervisory or trouble conditions with either the CP-3000A or the 5104B will be communicated off premises to a central station receiver.

7.2.2 Operation

When an alarm is received by the CP-3000A, one of the alarm relays A, B, C or D will trip and activate the appropriate zone on the 5104B communicator. The 5104B will transmit the notification to the central station. Acknowledging the alarm on the CP-3000A will only silence its internal sounder. The sounder on the 5104B CANNOT be silenced by pressing the ALARM ACK key on the CP-3000A or the Reset/Silence switch on the communicator. The 5104B will silence its sounder and fully reset only when the CP-3000A RESET key is pressed and the 5104B has finished communicating to the central station.

When a supervisory alarm is received by the CP-3000A, the Alarm C relay will short causing a supervisory transmission to be sent from Zone 4 on the 5104B. Acknowledging the supervisory on the CP-3000A will only silence its internal sounder. Pressing the Reset/Silence switch on the 5401B will silence its internal sounder. The 5104B will also silence its sounder and fully reset when the CP-3000A RESET key is pressed.

When a trouble is received by the CP-3000A, the N.C. trouble relays will open causing a trouble transmission to be sent from Zone 6 on the 5104B. Acknowledging the trouble on the CP-3000A will only silence its internal sounder. Pressing the Reset/Silence switch on the 5401B will silence its internal sounder. The 5104B will also silence its sounder and fully reset when the CP-3000A RESET key is pressed. Note: Central station notification of A/C loss in the CP-3000A will be delayed by 90 minutes. Central station notification of A/C loss in the 5104B will be delayed by 60 minutes. Two A/C loss signals will be transmitted off premises if both the CP-3000A and 5104B lose power simultaneously and both signals will be delayed by the times stated above.

If any trouble condition occurs as a result of a problem with the 5104B it will not be annunciated on the CP-3000A. The 5104B will communicate the trouble to the central station. The internal sounder on the 5104B can be silenced with the Reset/Silence switch on the 5104B unit. The 5104B will only restore to normal when the trouble condition is resolved.

Section 8 – Signal Survey

8.1 New Installation Survey

This survey method is to determine acceptable locations for devices, annunciators and repeaters prior to installing the equipment. It will also determine the quantity of repeaters required in the installation. You will need a minimum of one Model AR-3A repeater and one Model 340(TS) Fire transmitter to conduct the survey. The Model 340(TS) transmitter will serve as a repeater when conducting repeater to repeater signal tests. If the installation requires smoke detectors you will need one to conduct the survey. A magnet will also be required to activate the signal survey routine in the transmitters.

Begin by locating the dip switch SW2 on the repeater board. Refer to figure 4 for the switch location. Set dip switch #1 of SW2 to the right or off position. Switches 2-6 should be on or to the left. . Attach one of the compatible antennas to connector A then connect the batteries to the repeater. Refer to figure 4 in this manual for correct wiring. The repeater is now waiting to receive a survey transmission from any transmitter.

Begin by holding the repeater in the intended location of the CP-3000A facp. The first step is to survey the reception area of the control panel and which devices can report directly to it without a repeater. Use the type of transmitter that will be mounted in the location being tested. Install a battery in the transmitter to be tested and a single beep should be emitted from the transmitters sounder followed by two beeps indicating it has established communication with the repeater. The two beep confirmation signal must be heard before the survey can be conducted. If the single beep is heard but the two beeps are not, momentarily place a magnet next to the appropriate survey location of the transmitter being used. Once the initial beep is heard the magnet can be removed while waiting for the confirmation signal. Continue this until the one beep and two beep confirmation tones are both heard. Refer to the device manual to locate the magnet survey location of each transmitter. Once repeater device communication has been established the survey can begin.

Hold the device in the desired mounting location and initiate the survey signal test with the magnet held to the appropriate location on the device under test. The start of the survey is indicated by a single beep at the device and repeater. The end of the survey is indicated by either a single beep or two beeps at the device only. A single beep is the indication of an unacceptable survey and two

beeps indicates a successful survey. A minimum of 5 consecutive successful surveys with the device held in the mounting location must be accomplished to validate the location as an acceptable for mounting the device. If an unacceptable survey is the result then communications between the repeater and device being tested will have to be reestablished as described above to continue with the survey. Continue the survey until the range of the CP-3000A location is established.

Once the device locations exceed the range of the CP-3000A a repeater location will have to be determined to extend the installation to receive devices located outside the reception range of the CP-3000A. To test repeater to repeater communications use the repeater along with a Model 340(TS) Fire transmitter. The Fire Transmitter must be used to simulate the second repeater. Do not use any other transmitter for repeater to repeater testing. Choose a desired location for the first repeater. Hold the Fire Transmitter at the desired repeater location and test for a good survey as described above. A good survey must be established at this location before it can be used to locate a repeater and continue the survey. Once an acceptable location has been determined, hold the repeater at this location and continue to test devices for locations that result in acceptable surveys. When the range of this repeater has been exhausted, continue to test and add repeater locations as described until a good survey result is achieved for all the devices in the installation.

8.2 Existing Installation Survey

To check the signal of an existing device in an installation, momentarily place a magnet in the appropriate survey location of the device. Refer to the device manual for the survey location of each type of transmitter. One beep should be heard at the device and the repeater which received the survey signal followed by either a single beep or two beeps at the device only. A single beep indicates an unacceptable survey and two beeps indicate an acceptable survey. If an unacceptable survey is the result, the device will have to be relocated or a repeater added to receive it at this location. To test repeater to repeater communications, press the survey button located on the repeater circuit board for 1 second then release. Refer to figure 4 for the survey button location. The beeps that indicate the survey start and result are the same as a device. The repeater which received the survey signal will beep once. This is to notify the installer which repeater is responding to the device survey signal.

INDEX

A

Alarm 7, 8, 18, 31, 44, 45, 51, 54, 56
Alarm Ack..... 51, 66
Annunciator..... 10, 28
Antenna..... 9, 12, 13
Auxiliary 6, 8, 9, 44, 45, 51, 52, 54, 55

B

Batteries 9, 14, 18

C

Charger Fault 57
Class A..... 7, 9, 47
Class B 7, 9, 47
Clock..... 7
CO Detector 38
Communicator..... 7, 64

D

Description and Features..... 7
Dimensions 9
Dip switch 67
Disclaimer 2

E

Enclosure..... 9
Enrollment..... 8, 17
EOL Violation..... 57

F

Features 8

G

Ground Fault 57

H

Hardware Failure 57
Horns On..... 52

I

Ignored Device..... 41
Initiating Device. 7, 8, 10, 12, 18, 51, 53, 54, 56, 57,
58
Installation..... 12
Introduction..... 6

L

LCD display 7, 8, 52, 54, 55, 56
LED..... 50
Logs..... 56, 58, 59
Low Battery 57

M

Magnet 67, 68
Maintenance..... 57
Manual Service 10
Memory..... 7, 8, 54
Memory Error 58

N

NAC Circuit..... 7, 8, 20, 47, 50, 51, 52, 54, 55, 57
NFPA 6, 12
Non Power Limited..... 9, 47
Notification Appliance..... 10, 18, 47, 48

O

Omni 13
Operating Frequency..... 9
Operating Humidity 9
Operating Temperature 9

P

Panel Test..... 52
Password 8
Piezo..... 7, 51, 52, 53
Power Limited..... 13, 44, 45
Power Loss..... 57
Power Source 9
Power Up Reset..... 57
Program Fault..... 57
Programming7, 18, 20, 45, 47, 49, 50, 52, 55, 62, 65

R

Receiver 15, 18, 47
Relays..... 44, 51, 52, 54, 56
Remote reset..... 40
Repeater 7, 13, 18, 20, 41, 44, 54, 57
Reset..... 52

S

Signal Silence..... 51
Signal Survey 12, 13, 17, 67, 68

Signals..... 7, 8, 54, 55, 56, 58
 Smoke Detector..... 7, 8, 44, 57
 Smoke Detector Silence 52
 Soft Keys..... 52
 Sounder 7, 51, 53, 54, 55, 56, 67
 Specifications 9
 Strobe Reset 52
 Supervisory 7, 44, 45, 54, 55
 Supervisory Ack..... 51
 Survey Button 68
 System Test..... 58

T

Tamper 57
 Tamper/Maint 57
 Tandem 7
 Test Failure 57
 Transformer..... 13, 15

Transmission Format 9
 Transmitter 68
 Trouble..... 7, 8, 12, 44, 45, 51, 54, 56, 58
 Trouble Ack 51

U

UL 6, 7, 10, 48
 Unacceptable survey 68
 Unknown Device 41
 Unknown Unit..... 57

W

Weight..... 9
 Wire..... 13, 18, 44, 45

Y

Yagi..... 13

MODEL CP-3000A OPERATING INSTRUCTIONS

To acknowledge Alarms press the ALARM ACK button.

To view lower priority Alarms press the Alarm ACK button after acknowledging the Alarms.

To view multiple pages of Alarms press the PAGE UP or PAGE DOWN soft keys.

To acknowledge Supervisory Alarms press the SUPERVISORY ACK button.

To view multiple pages of Supervisory Alarms press the PAGE UP or PAGE DOWN soft keys.

To acknowledge Trouble signals press the TROUBLE ACK button.

To view multiple pages of Trouble signals press the PAGE UP or PAGE DOWN soft keys.

To activate evacuation horns press the HORNS ON button.

To silence evacuation horns press the SIGNAL SILENCE button.

To silence tandem smoke detector sounders press the SMOKE DETECTOR SILENCE button.

To deactivate strobes press the STROBE RESET button.

To reset all outputs and the CP-3000A press the RESET button.

To place the CP-3000A in test mode press the TEST button.

To exit test mode press the RESET button

Local representative

Name: _____

Address: _____

Phone number: _____

This page must be framed and mounted adjacent to the CP-3000A for reference.

P/N IM-C3KA-OP Rev. A